

Low Voltage AC Drives for HVAC Applications

FRENIC-eHVAC



Efficient for Ecology

"eHVAC"

eHVAC High performance enabled by the comprehensive use of Fuji technology.
Easy maintenance for the end-user. Maintains safety and protects the environment. Opens up possibilities for the new generation.

Efficient for Ecology

FRENIC-*e*HVAC

As awareness of the environment that surrounds us has increased in recent years, we have seen a further push to accelerate the energy-saving trends required by buildings, factories and workplaces.

Fuji Electric's new FRENIC-eHVAC offers optimum capability in terms of energy saving for fans and pumps used in HVAC applications, eliminates waste through appropriate flow rate and air flow adjustments, and greatly influences power conservation and cost reductions through energy saving.



FRENIC-eHVAC

eHVAC High performance enabled by the comprehensive use of Fuji technology.
Easy maintenance for the end-user. Maintains safety and protects the environment.
Opens up possibilities for the new generation.



FRENIC-eHVAC helps bring you the energy-savings you require with optimum control of HVAC applications. It is the optimum product for the control of fans and pumps such as supply and exhaust fans and water supply pumps for HVAC devices such as AHUs (air handling units), chillers, and cooling towers.

Features



Pursuit of cost competitiveness

Competitiveness realized with optimum design.



Dedicated functionality for HVAC markets

Fire mode (fan control), built-in PID/Cascade operation (pump control), etc.



Built-in EMC filter as standard

Built-in category C2/C3 EMC filter as standard, catering for a variety of environments.



PM motor drive possible

PM motor drive is now possible with PM sensorless vector control.



Enhanced customized logic

Equipped with customized logic as standard to facilitate the free programming of up to 200 steps.

Unique functions tailored to the application or usage method can be constructed.



Comprehensive communication support

Equipped with BACnet communication protocol as standard to facilitate the productization of a variety of control and communication options.

Construction of system support is made easy with these functions.

- Standard support: RS485, Modbus RTU, BACnet MS/TP, METASYS N2
- Option support: Profibus DP, DeviceNet, Lonworks, CC-Link



Multi-function keypad (option)

A multi-function keypad with support for 19 languages is available as an option to realize worldwide deployment.

HVAC application examples

FRENIC-eHVAC plays a vital role in a variety of HVAC applications, helping to make all our lives that little bit easier.



VENTILATION

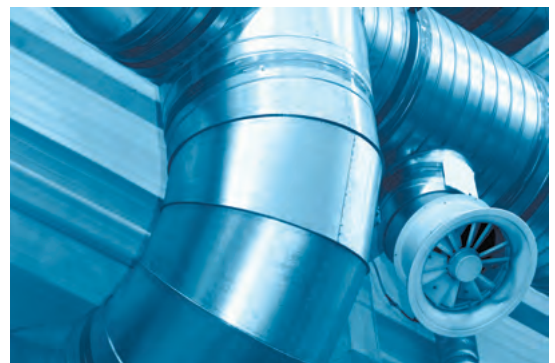
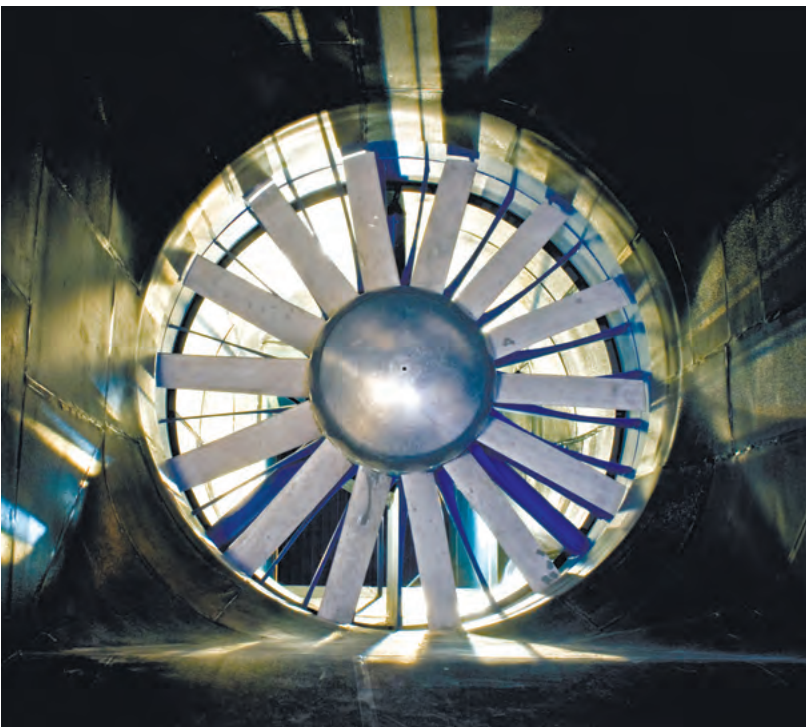



AIR CONDITIONING



PUMPING



Equipped with Functions for Air Conditioning Equipment and Water Treatment Equipment

Customized logic

The customized logic interface function is provided to the inverter body. This enables forming of logic circuit and arithmetic circuit to the digital and analog input and output signals, allowing simple relay sequence to be built while processing the signals freely.

Example

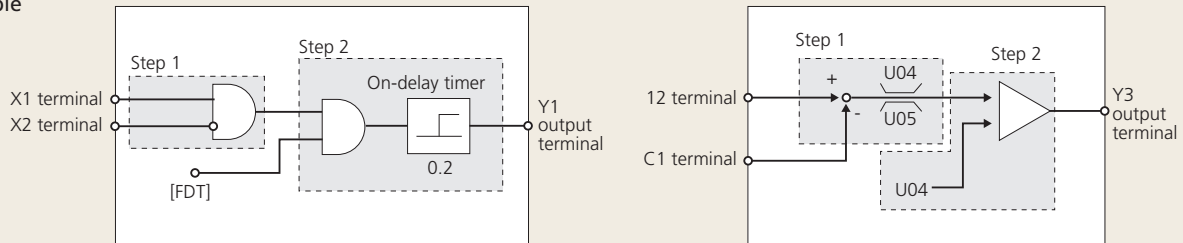

Standard 2PID control

The 2PID control is featured as standard. One PID module is used to control the output frequency of the inverter, and the other three PIDs can be used to control the external system. To utilize all of two PIDs, the optional card (OPC-AIO) needs to be mounted.

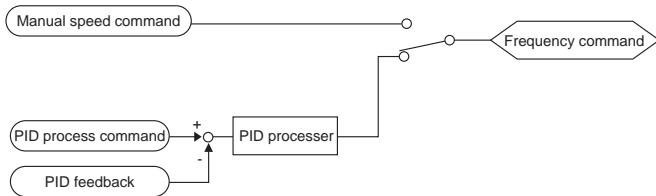

Fire mode (forced operation)

This mode ignores (retry) the inverter protection function to continue the operation. In that way, the inverter keeps operating the fan and pump as much as possible in case of emergency such as fire.

Password

Function codes can be read/write, displayed or hidden by setting the two passwords. This prevents erroneous operation or overwriting of function codes. In addition, if a wrong password was input exceeding the specified number of times, the inverter is restricted from operating as the user is regarded as improper.



Pick-up operation function

The pick-up operation function enables smooth starts. If you wish to run a fan currently not run by the inverter and in idle mode, this function searches the speed regardless of the direction of rotation and pick up the motion smoothly. This function allows for smooth operation such as when switching the power supply from the commercial power to inverter in a momentary action.

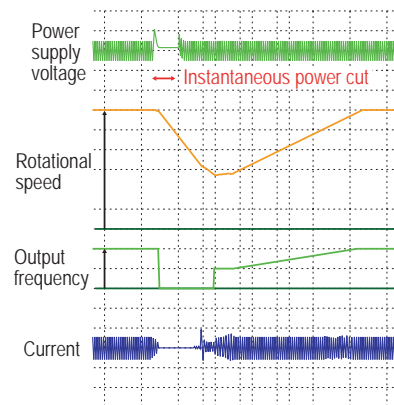



Cascade control

The cascade control is the function that controls the multiple pumps by one inverter. The pumps are controlled with combination of inverter drive and commercial drive. This can be applied in a large-scale water treatment plant.

In cascade control, the signals of flow rate and pressure sensors are controlled by the PID regulator that is built in the inverter. Each pump is driven either by the inverter or commercially according to the switching signal from the inverter. The pumps are controlled only by the inverter when the discharge volume is small, and adding to the inverter drive, they are controlled using commercial drive by adding them one by one as the discharge volume gets larger in order to ensure the required discharge volume in total. There are two following methods in control: inverter drive motor fixed method and inverter drive motor fixed method.

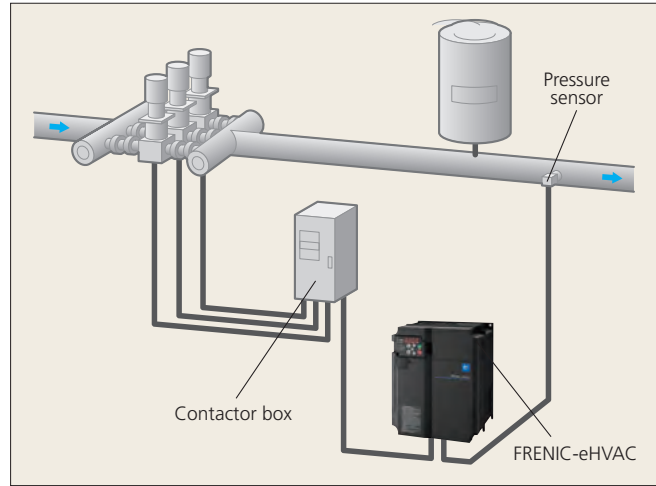

1. Inverter drive motor fixed method (FIXED)

The system is configured by combining the motor driven by the inverter (M0), motors that are commercially driven (M1 to M4) and auxiliary motor (MA). The motor driven by the inverter is always fixed as motor M0. Motors commercially driven are added one by one in control when the required discharge flow rate cannot be achieved with the motor M0 only.

Inverter drive motor fixed method (FIXED)

Max. 1 unit (Driven by inverter) + **4 units** (Commercially driven) + **1 unit** (Auxiliary motor)

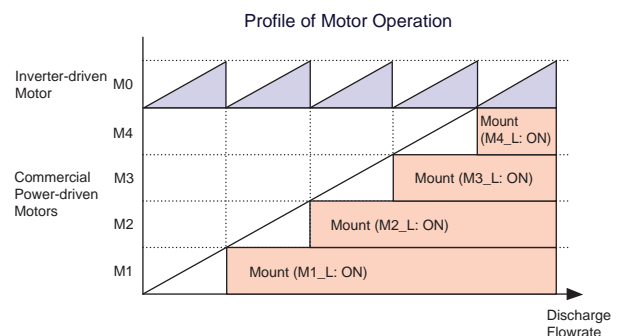
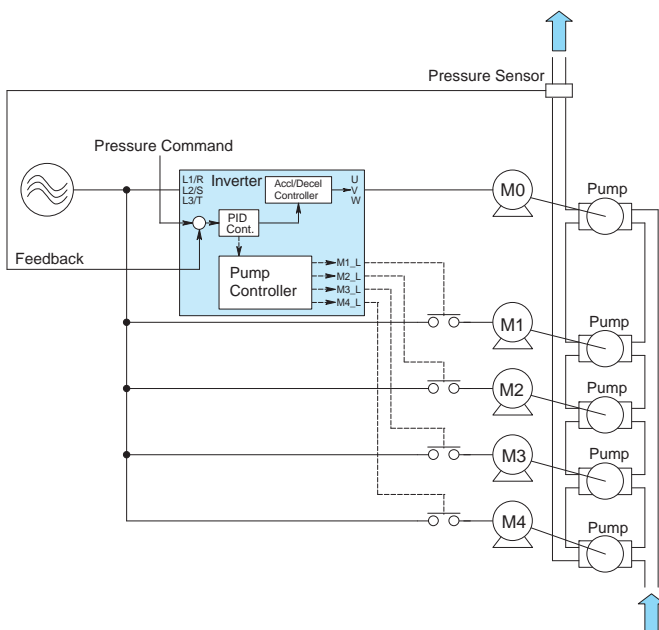



2. Inverter drive motor floating method (FLOATING)

The system for this method is configured by combining the motors that can be switched between inverter drive and commercial drive (M1 to M3) and auxiliary motor that are commercially driven (MA). The motors are driven by the inverter with variable speed control at start. When the desired discharge flow rate cannot be achieved with the first motor, operations FLOATING-1 or FLOATING-2 can be selected.

Inverter drive motor floating method (FLOATING)

Max. 3 units + 1 unit (Auxiliary motor)

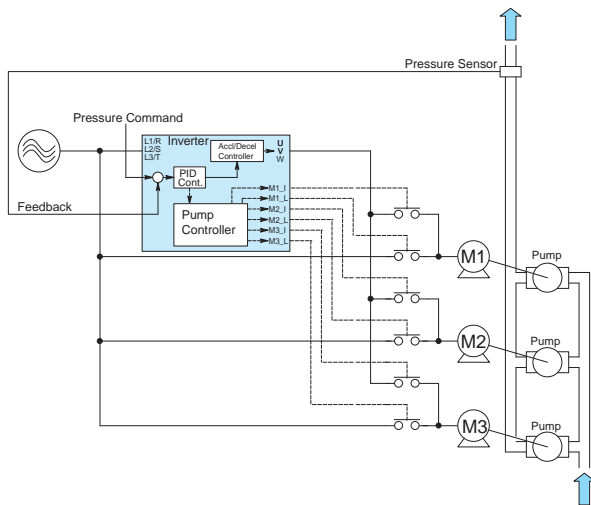

FLOATING-1

The first motor:

Switched as a commercially driven motor

Second and subsequent motors:

Operated by inverter drive

The inverter-driven motor is changed by rotation as the motor is added.

FLOATING-2

The first motor: Inverter drive continued

Second and subsequent motors: Commercially driven

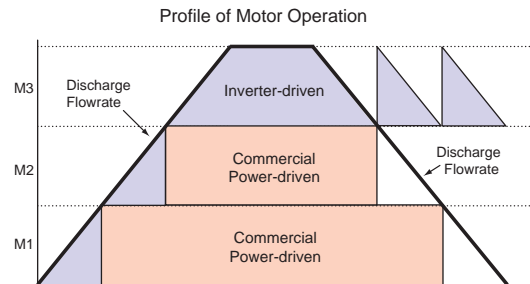

Mutual operation

Parallel operation of multiple inverters is possible by connecting inverters via RS485 communication. Up to three slave inverters can be connected with a single master inverter. The control method can be selected from the inverter drive motor floating method and all motor simultaneous PID control method. Furthermore, even in the event that the master inverter stops following an inverter alarm, master PID calculation continues, commands continue to be sent to the slave inverters, and operation can be continued with the slave inverters only.

■ Communications linked inverter drive motor floating method

When the inverter output frequency increases, and conditions for increasing the number of inverters are met, the second inverter starts up. A total of four inverters start up sequentially.

■ Communications linked all motor simultaneous PID control method

With this method, PID control is performed for all inverters simultaneously at the same frequency.

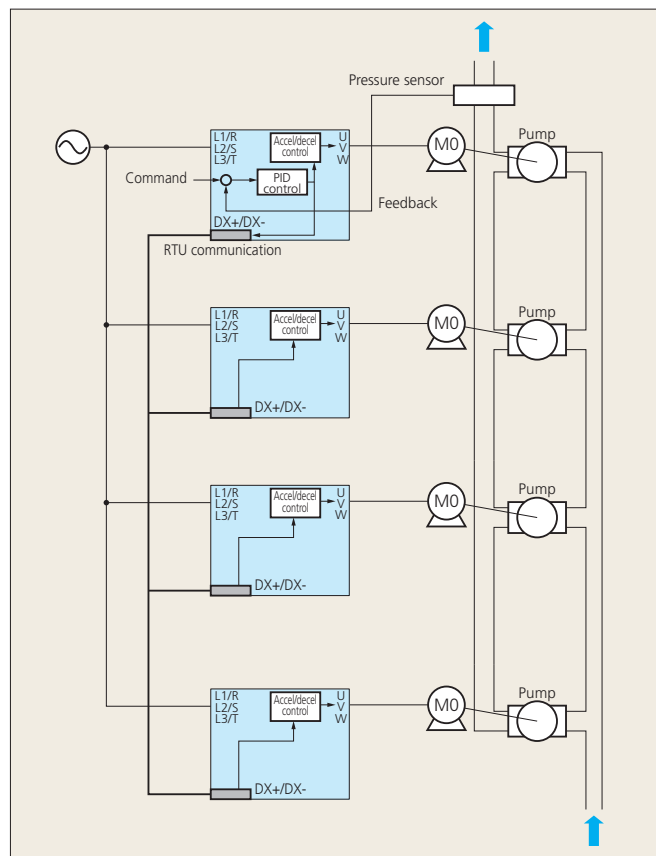

How to read the model number

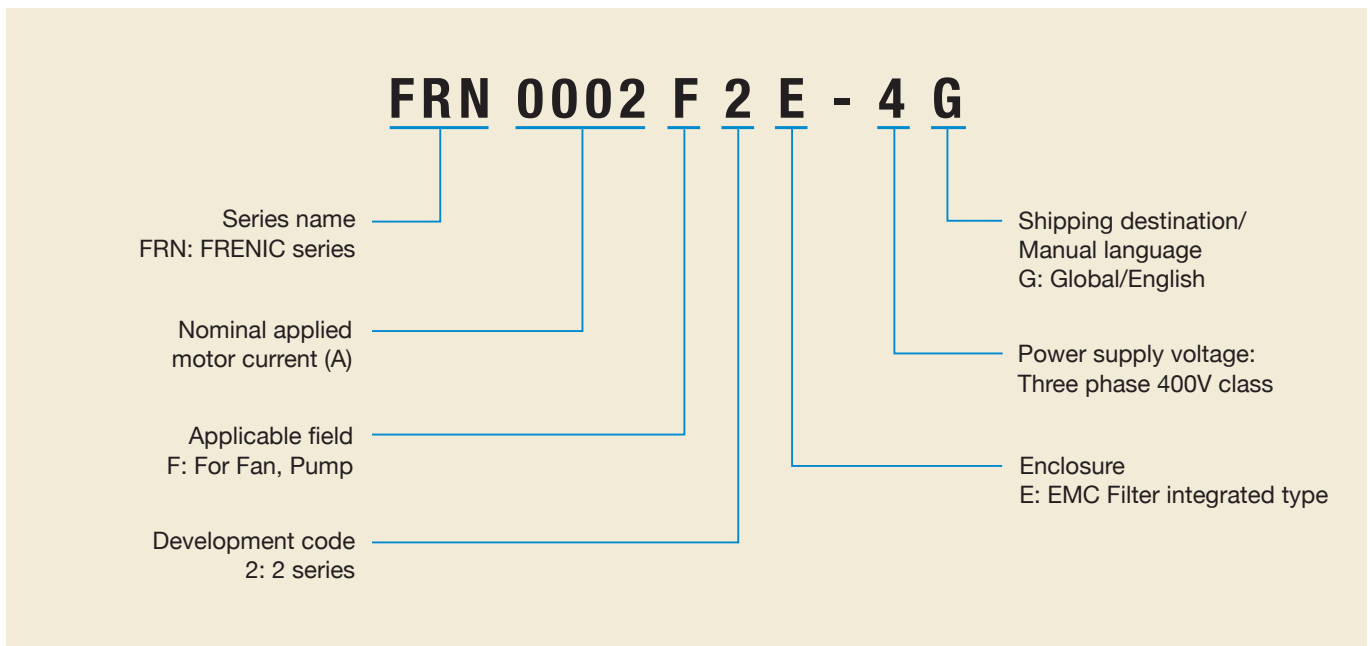

Model variation

Rated voltage	Nominal applied motor (kW)	Type	Degree of protection
3-phase 400V	0.75	FRN0002F2E-4G	IP20
	1.1	FRN0003F2E-4G	
	2.2	FRN0005F2E-4G	
	3	FRN0006F2E-4G	
	5.5	FRN0011F2E-4G	
	7.5	FRN0018F2E-4G	
	11	FRN0023F2E-4G	
	15	FRN0031F2E-4G	
	18.5	FRN0038F2E-4G	
	22	FRN0045F2E-4G	
	30	FRN0060F2E-4G	IP00
	37	FRN0075F2E-4G	
	45	FRN0091F2E-4G	
	55	FRN0112F2E-4G	
	75	FRN0150F2E-4G	
	90	FRN0176F2E-4G	
	110	FRN0210F2E-4G	
	132	FRN0253F2E-4G	
	160	FRN0304F2E-4G	
	200	FRN0377F2E-4G	
220	FRN0415F2E-4G		
280	FRN0520F2E-4G		

Standard specifications

Three phase 400V class series (EMC Filter Built-in Type)

Item		Specifications										
Type	FRN □□□□ F2E-4G	0002	0003	0005	0006 ⁹	0011 ⁹	0018	0023	0031	0038	0045	0060
Nominal applied motor [kW] ¹		0.75	1.1	2.2	3.0	5.5	7.5	11	15	18.5	22	30
Output ratings	Rated capacity [kVA] ²	1.3	2.5	3.8	4.8	8.4	13	17	23	28	34	45
	Rated voltage [V] ³	Three-phase 380 to 480V (With AVR)										
	Rated current [A]	1.8	3.4	5.0	6.3	11.1	17.5	23	31	38	45	60
	Overload capability	120% of nominal current for 1min										
Input ratings	Main power supply	Three-phase 380 to 480V, 50/60Hz										
	Voltage/frequency variations	Voltage: +10 to -15% (Voltage unbalance:2% or less ⁸ , Frequency: +5 to -5%)										
	Rated current without DCR [A] ⁵	2.7	3.9	7.3	11.3	16.8	23.2	33.0	43.8	52.3	60.6	77.9
	Rated current with DCR [A] ⁵	1.5	2.1	4.2	5.8	10.1	14.4	21.1	28.8	35.5	42.2	57.0
Required power supply capacity [kVA] ⁶		1.1	1.5	3.0	4.1	7.0	10	15	20	25	30	40
Braking	Braking torque [%] ⁷	53%	68%	48%	29%	27%	15%					
	DC braking	Starting frequency: 0.0 to 60.0Hz, Braking time: 0.0 to 30.0s, Braking level: 0 to 80% of nominal current										
	Braking chopper	Built-in										
	Minimum connection resistance [ohm]	200		160		130	80	60	40	34.4		16
Braking resistor		Option										
EMC filter		Compliant with EMC Directives, Emission: Category C2. Immunity: 2nd Env. (EN61800-3:2004+A1:2012)					Compliant with EMC Directives, Emission: Category C3. Immunity: 2nd Env. (EN61800-3:2004+A1:2012)					
DC reactor (DCR)		Option										
Enclosure (IEC60529)		IP20, UL open type										
Cooling method		Natural cooling					Fan cooling					
Mass [kg]		1.5	1.8	2.3	2.3	2.4	6.5	6.5	11.2	11.2	10.5	11.2

Item		Specifications										
Type	FRN □□□□ F2E-4G	0075	0091	0112	0150	0176	0210	0253	0304	0377	0415	0520
Nominal applied motor [kW] ¹		37	45	55	75	90	110	132	160	200	220	280
Output ratings	Rated capacity [kVA] ²	57	69	85	114	134	160	192	231	287	316	396
	Rated voltage [V] ³	Three-phase 380 to 480V (With AVR)										
	Rated current [A]	75	91	112	150	176	210	253	304	377	415	520
	Overload capability	120% of nominal current for 1min										
Input ratings	Main power supply	Three-phase 380 to 480V, 50/60Hz					Three-phase 380 to 440V, 50Hz Three-phase 380 to 480V, 60Hz ¹⁰					
	Voltage/frequency variations	Voltage: +10 to -15% (Voltage unbalance:2% or less ⁸ , Frequency: +5 to -5%)										
	Rated current without DCR [A] ⁵	94.3	114	140	—	—	—	—	—	—	—	—
	Rated current with DCR [A] ⁵	68.5	83.2	102	138	164	201	238	286	357	390	500
Required power supply capacity [kVA] ⁶		48	58	71	96	114	140	165	199	248	271	347
Braking	Braking torque [%] ⁷	7 to 12%										
	DC braking	Starting frequency: 0.0 to 60.0Hz, Braking time: 0.0 to 30.0s, Braking level: 0 to 80% of nominal current										
	Braking chopper	Option										
	Minimum connection resistance [ohm]	—	—	—	—	—	—	—	—	—	—	—
Braking resistor		Option										
EMC filter		Compliant with EMC Directives, Emission: Category C3. Immunity: 2nd Env. (EN61800-3:2004+A1:2012)										
DC reactor (DCR)		Option					Option (Please be sure to connect DC reactor)					
Enclosure (IEC60529)		IP00, UL open type										
Cooling method		Fan cooling										
Mass [kg]		26	27	31	33	40	62	63	95	96	130	140

¹ When selecting the inverter rating for Fuji 4-pole standard motor, consider not only the rating capacity(kW) is enough but also inverter output current is larger than selected the motor's nominal current.

² Rated capacity is calculated by assuming the output rated voltage as 440 V.

³ Output voltage cannot exceed the power supply voltage.

⁴ When the carrier frequency (F26) is set to below value or higher, the inverter is sure to be necessary to derate its nominal current. Type 0002 to 0011:8kHz, type 0018 to 0045:10kHz, type 0060 to 0150:6kHz, type 0176 to 0520:4kHz

⁵ The value is calculated assuming that the inverter is connected with a power supply with the capacity of 500 kVA (or 10 times the inverter capacity if the inverter capacity exceeds 50 kVA) and %X is 5%. Be sure to use the DCR when applicable motor capacity is 75kW or above.

⁶ Obtained when a DC reactor (DCR) is used.

⁷ Average braking torque for the motor running alone. (It varies with the efficiency of the motor.)







⁸ Voltage unbalance (%)=(Max. voltage (V) - Min. voltage (V))/Three -phase average voltage (V) × 67 (IEC 61800 - 3) If this value is 2 to 3%, use an optional AC reactor (ACR).

⁹ Type 0006 and 0011: allowable ambient temperature 40°C (+104 °F) or less.

The rated output current is decreased 1% for every 1 °C (1.8 °F) when ambient temperature is +40°C (+104 °F) or more.

¹⁰ The 400 V class series with type 0176 or above is equipped with a set of switching connectors (male) which should be configured according to the power source voltage and frequency.

Common specifications

Items	Specifications	Remarks
Maximum frequency	• 25 to 120 Hz variable(V/f control mode, Magnetic pole position sensorless vector control mode)	
Base frequency	• 25 to 120 Hz variable	
Starting frequency	• 0.1 to 60.0 Hz variable	
Carrier frequency	<ul style="list-style-type: none"> • Three phase 400V class <ul style="list-style-type: none"> - Type 0002 to 0045: - Type 0060 to 0150: - Type 0176 or above type of capacity: - 0.75 to 16kHz variable - 0.75 to 10kHz variable - 0.75 to 6kHz variable Note: Carrier frequency drops automatically to protect the inverter depending on environmental temperature and output current. (This auto drop function can be canceled.) 	
Output frequency Accuracy (Stability)	<ul style="list-style-type: none"> • Analog setting: $\pm 0.2\%$ of maximum frequency (at $25 \pm 10^\circ\text{C}$) ($77 \pm 18^\circ\text{F}$) • Keypad setting: $\pm 0.01\%$ of maximum frequency (at -10 to $+50^\circ\text{C}$) (14 to 122°F) 	
Frequency setting resolution	<ul style="list-style-type: none"> • Analog setting: 0.05% of maximum frequency • Keypad setting: 0.01 Hz (99.99 Hz or less), 0.1 Hz (100.0 to 120.0 Hz) • Link setting: 0.005% of maximum frequency or 0.01 Hz (fixed) 	
Speed control range	• 1 : 10 (Minimum speed : Nominal speed, 6-pole, 180 to 1800 r/min)	PM-SVC
Speed control accuracy	<ul style="list-style-type: none"> • Analog setting: $\pm 0.5\%$ of maximum frequency or below (at $25 \pm 10^\circ\text{C}$) ($77 \pm 18^\circ\text{F}$) • Digital setting: $\pm 0.5\%$ of base frequency or below (at -10 to $+50^\circ\text{C}$) (14 to 122°F) 	PM-SVC
Control method	<ul style="list-style-type: none"> • V/f control • Vector control without magnetic pole position sensor 	VF PM-SVC
Voltage/frequency characteristic	<ul style="list-style-type: none"> • Possible to set output voltage at base frequency and at maximum output frequency (160 to 500 V). • Non-linear V/f setting (2 points): Free voltage (0 to 500 V) and frequency (0 to 120 Hz) can be set. 	
Torque boost	<ul style="list-style-type: none"> • Auto torque boost (For constant torque load) • Manual torque boost: Torque boost value can be set between 0.0 and 20.0%. • Select application load with the function code. (Variable torque load or constant torque load) 	
Starting torque	• Three phase 400V class : 50% or higher	
Start/stop operation	<ul style="list-style-type: none"> • Keypad : Start and stop with  and  keys (Standard keypad) Start and stop with   and  keys (Option multi-functional keypad) • External signals (digital inputs) : Forward (Reverse) rotation, stop command (capable of 3-wire operation), coast-to-stop command, external alarm, alarm reset, etc. • Link operation : Operation through RS-485 or field bus (option) communications. • Switching operation command : Remote/Local switching, link switching. 	
Frequency setting	<ul style="list-style-type: none"> • Keypad : Settable with  and  keys • External Volume : Available to be set with external frequency command potentiometer. (1 to 5 kΩ 1/2 W) • Analog input : 0 to ± 10 VDC (± 5 VDC)/ 0 to $\pm 100\%$ (terminal [12]) 0 to +10 VDC (+5 VDC)/ 0 to +100% (terminal [12]) +4 to +20 mADC/ 0 to 100% (terminal [C1]) +4 to +20 mADC/ -100 to 0 to 100% (terminal [C1]) 0 to +20 mADC/ 0 to 100% (terminal [C1]) 0 to +20 mADC/ -100 to 0 to 100% (terminal [C1]) 0 to +10 VDC (+5 VDC)/ 0 to +100% (terminal [V2]) 0 to +10 VDC (+5 VDC)/ -100 to 0 to +100% (terminal [V2]) • UP/DOWN operation : Frequency can be increased or decreased while the digital input signal is ON. • Multi-step frequency : Selectable from 16 different frequencies (step 0 to 15) • Pattern Operation Mode : Mode: Automatically run in accordance with the previously configured running time, rotation direction, acceleration/deceleration and reference frequency. Maximum allowable settings are 7 stages. • Link operation : Can be specified via built-in RS-485 or field bus communications. (Option) • Switching frequency setting source : Two of frequency settings source can be switched with an external signal(digital input). Remote/local switching, Link switching Auxiliary frequency setting: Inputs at terminals [12], [C1] or [V2] can be added to the main setting as auxiliary frequency settings. • Inverse operation : Switchable from "0 to +10 VDC/0 to 100%" to "+10 to 0 VDC/0 to 100%" by external command. (terminals [12], [V2]) : Switchable from "0 to -10 VDC/0 to -100%" to "-10 to 0 VDC/0 to -100%" by external command.(terminal [12]) : Switchable from "4 to +20 mADC/0 to 100%" to "+20 to 4 mADC/0 to 100%" by external command.(terminal [C1]) : Switchable from "0 to +20 mADC/0 to 100%" to "+20 to 0 mADC/0 to 100%" by external command.(terminal [C1]) • Pulse train input (standard) : Pulse input = Terminal [X5]. Rotational direction = Another input terminal except [X5]. Complementary output: Max. 100 kHz, Open collector output: Max. 30 kHz 	Analog input between DC+1 to +5V is available with analog bias/gain function.
Acceleration/ deceleration time	<ul style="list-style-type: none"> • Setting range : From 0.00 to 3600 s • Switching : The four types of acceleration/deceleration time can be set or selected individually (switchable during operation). • Acceleration/deceleration pattern : Linear acceleration/deceleration, S-shape acceleration/deceleration (weak, free (set by function codes)), curvilinear acceleration/deceleration • Deceleration mode (coast-to-stop) : Shut-off of the run command makes the motor coast to a stop. • Deceleration time for forcible stop : Deceleration stop by the forcible stop (STOP). S-curve will be canceled during "Force to Stop". 	
Frequency limiter (Upper limit and lower limit frequencies)	<ul style="list-style-type: none"> • Specifies the upper and lower limits in Hz. • Selectable for the operation performed when the reference frequency drops below the lower limit specified by related function code. 	
Bias for frequency/ PID command	• Bias of set frequency and PID command can be independently set(setting range: 0 to $\pm 100\%$).	
Analog input	<ul style="list-style-type: none"> • Gain : Set in the range from 0 to 200% • Off-set : Set in the range from -5.0 to +5.0% • Filter : Set in the range from 0.00s to 5.00 s • Polarity : Select from \pm or + 	
Jump frequency	• Three operation points and their common jump width (0.0 to 30.0 Hz) can be set.	

Common specifications

Items	Specifications	Remarks
Auto-restart after momentary power failure	<ul style="list-style-type: none"> • Trip at power failure : The inverter trips immediately after power failure. • Trip at power recovery : Coast-to-stop at power failure and trip at power recovery. • Deceleration stop : Deceleration stop at power failure, and trip after stoppage. • Continue to run : Operation is continued using the load inertia energy. • Start at the frequency selected before momentary power failure : Coast-to-stop at power failure and start after power recovery at the frequency selected before momentary stop. • Start at starting frequency : Coast-to-stop at power failure and start at the starting frequency after power recovery. • Start at the searched frequency : Coast-to-stop at power failure and start at the searched frequency after power recovery. 	
Hardware current limiter	<ul style="list-style-type: none"> • Limits the current by hardware to prevent an overcurrent trip caused by fast load variation or momentary power failure, which cannot be covered by the software current limiter. This limiter can be canceled. 	
Software current limiter	<ul style="list-style-type: none"> • Automatically reduces the frequency so that the output current becomes lower than the preset operation level. • This limiter can be canceled. 	
Operation by commercial power supply	<ul style="list-style-type: none"> • With commercial power selection command, the inverter outputs 50/60 Hz (SW50, SW60). • The inverter has the commercial power supply selection sequence. 	
Torque limiter	<ul style="list-style-type: none"> • Control output torque so that output torque is preset limiting value or less. • Switchable between 1st and 2nd torque limit values. 	
PID control	<p>PID processor for process control Normal operation/inverse operation</p> <ul style="list-style-type: none"> • PID command: Keypad, analog input (from terminals [12], [C1] and [V2]), Multi-step setting(Selectable from 3 points), RS-485 communication • PID feedback value (from terminals [12], [C1] and [V2]) • Alarm output (absolute value alarm, deviation alarm) • Slow flowrate stop function • Anti-reset wind-up function • PID output limiter • Integration reset/hold 	
Auto-reset	<ul style="list-style-type: none"> • The auto-reset function that makes the inverter automatically attempt to reset the tripped state and restart without issuing an alarm output (for any alarm) even if any protective function subject to reset is activated. • The allowable maximum number of reset times for the inverter to automatically attempt to escape the tripped state is 20. 	
Auto search for idling motor speed	<ul style="list-style-type: none"> • The inverter automatically searches for the idling motor speed to start to drive without stopping. (Motor constants must be needed tuning: Auto-tuning (offline)) 	
Automatic deceleration	<ul style="list-style-type: none"> • If the DC link bus voltage or calculated torque exceeds the automatic deceleration level during deceleration, the inverter automatically prolongs the deceleration time to avoid overvoltage trip. (It is possible to select forcible deceleration actuated when the deceleration time becomes three times longer.) • If the calculated torque exceeds automatic deceleration level during constant speed operation, the inverter avoids overvoltage trip by increasing the frequency. 	
Deceleration characteristic (improved braking capacity)	<ul style="list-style-type: none"> • The motor loss is increased during deceleration to reduce the regenerative energy in the inverter to avoid overvoltage trip. 	Cancelled at PMSVC
Auto energy saving operation	<ul style="list-style-type: none"> • The output voltage is controlled to minimize the total power loss of the motor and the inverter at a constant speed. 	Exclusive high efficiency control at PM-SVC
Overload prevention control	<ul style="list-style-type: none"> • If the ambient temperature or internal IGBT junction temperature is almost near the overheat level due to overload, the inverter drops its output frequency automatically in order to escape overload situation. 	
Auto-tuning (off-line)	<ul style="list-style-type: none"> • Measures the motor parameters while the motor is stopped or running, for setting up motor parameters. Tuning mode to only identify %R1 and %X. Tuning mode to identify the parameters for PM motor. 	
Cooling fan ON/OFF control	<ul style="list-style-type: none"> • Detects inverter internal temperature and stops cooling fan when the temperature is low. • Fan control signal can be output to an external device. 	
Universal DI	<ul style="list-style-type: none"> • The status of external digital signal connected with the universal digital input terminal is transferred to the host controller. 	
Universal DO	<ul style="list-style-type: none"> • Digital command signal from the host controller is output to the universal digital output terminal. 	
Universal AO	<ul style="list-style-type: none"> • The analog command signal from the host controller is output to the analog output terminal. 	
Speed control	<ul style="list-style-type: none"> • Selectable among the two set of the auto speed regulator (ASR) parameters. 	PM-SVC
DC braking	<ul style="list-style-type: none"> • When the run command turns OFF and the motor speed fall below the preset DC braking starting speed, the inverter starts to inject DC current into the motor in order to stop the motor. • When the run command turns ON, the inverter starts to inject DC current into the motor in order to pre-excite. 	
Rotational direction control	<ul style="list-style-type: none"> • Select either of reverse or forward rotation prevention. 	
Dew condensation prevention	<ul style="list-style-type: none"> • When the motor is stopped, current is automatically supplied to the motor to keep the motor warm and avoid condensation. 	
Customizable logic interface	<p>The digital logic circuits and an analog arithmetic circuits can be chosen and connected with digital/analog input/output signals.</p> <ul style="list-style-type: none"> • Logic circuit: (Digital) AND, OR, XOR, flip-flops, rising/falling edge detection, counters, etc. (Analog) Addition, subtraction, multiplication, division, limiter, absolute value, sign inversion addition, comparison, highest selection, lowest selection, average value, measure conversion . • Multifunctional timer: On-delay, off-delay, pulse train, etc. Setting range: 0.0 to 9990 s • Input/output signal: Terminal input/output(Digital and Analog), logic circuit output, inverter command/monitor data • Others: The 200 steps are available. Output/input of each steps can be connected. 	
Applicable functions for - Constant temperature difference control - Presumed terminal pressure control	<ul style="list-style-type: none"> • The specific functions which are suitable for each application field are realized by customizable logics. 	
Pump number control	<ul style="list-style-type: none"> • Possible to operate a water system with optimal power by controlling a number of pumps. Inverter-driven fixed system Maximum number of units in control: 5 One pump driven by inverter at variable speed (fixed), up to three pumps driven by commercial power (fixed), and one auxiliary pump (driven by commercial power) (fixed) • Inverter-driven circulation system Maximum number of units in control: 3 One pump driven by inverter at variable speed (circulation), up to two pumps driven by commercial power (circulation) (the relay output interface card (optional) is required in the case of the circulation operation of three pumps), and oneauxiliary pump (driven by commercial power) (fixed) • Communications link system Maximum number of units in control: 4 Up to four pumps driven by inverter at variable speed (all units under inverter variable speed control) (Each pump requires an inverter.) 	
Password function	<ul style="list-style-type: none"> • Possible to hide the display of data or prevent setting changes caused by unintended control (possible to set in two levels). 	
Data initialization	<ul style="list-style-type: none"> • Selectable from "Factory default value" and "User initial value" 	
External PID Control	<ul style="list-style-type: none"> • PID processor for process control • Normal operation/inverse operation • PID command: Keypad, analog input (from terminals [12], [C1] and [V2]), Multi-step setting(Selectable from 3 points), RS-485 communication • PID feedback value (from terminals [12], [C1] and [V2]) • Alarm output (absolute value alarm, deviation alarm) • PID feedback error detection • Sensor input quantity scaling function • PID output limiter • Integral reset/hold function • Anti-reset windup function 	
Fire mode	<ul style="list-style-type: none"> • Continues operation without alarm by retry. 	

	Items	Specifications	Remarks
	Display	Detachable with 7 segments LEDs (4 digits) , 7 keys(PRG/RESET, FUNC/DATA, UP, DOWN, RUN, STOP, SHIFT) and 6LED indicator (KEYPAD CONTROL, Hz, A, kW, x10, RUN)	
	Running/Stopping	<ul style="list-style-type: none"> • Speed monitor (reference frequency, output frequency, motor speed, load shaft speed, line speed, and speed indication with percent), Output current in RMS[A], Output voltage in RMS[V], Calculated torque [%], Input power [kW], PID command value, PID feedback value, PID output, Load factor [%], Motor output [kW] • Analog input monitor, input watt-hour, external PID1 command value (final), external PID1 feedback amount, external PID1 output, and manual external PID1 command value can be displayed. <ul style="list-style-type: none"> • Output frequency : Output frequency • Output frequency : Output frequency (final) • Output current : Output current in RMS. • Output voltage : Output voltage in RMS. • Calculated torque : Calculated output torque of the motor in %. • Reference frequency : Frequency specified by a frequency command. • Rotational direction : Rotational direction indicated. F: forward, r: reverse, ----: stop • Running status : Running status in 4-digit hexadecimal format. • Motor speed : Displayed value = (Output frequency Hz) × 120 / (No. of poles) If the value is 10000 or larger, the x10 LED turns ON and the LED monitor shows one-tenth of the value. • Load shaft speed : Displayed value = (Output frequency Hz) × (Function code E50:Coefficient for speed indication) If the value is 10000 or larger, the x10 LED turns ON and the LED monitor shows one-tenth of the value. • PID command value : Physical quantity (e.g., temperature or pressure) of the object to be controlled, which is converted from the PID command value using function code. If PID control is disabled, "----" appears. • PID feedback amount : Physical quantity (e.g., temperature or pressure) of the object to be controlled, which is converted from the PID feedback amount using function code. If PID control is disabled, "----" appears. • Torque limit value : Driving torque limit value A (based on motor rated torque). Braking torque limit value B (based on motor rated torque). • PID output value : PID output value in %. (100% means the maximum frequency) If PID control is disabled, "----" appears. • Running status 2 : Running status 2 in 4-digit hexadecimal format. 	
	Life early warning	<ul style="list-style-type: none"> • The life early warning of the main circuit capacitors, capacitors on the PCBs and the cooling fan can be displayed. • An external output is issued in a transistor output signal. • Outputs the warning when the maintenance time or the number of start times has exceeded the preset. • Ambient temperature: 40°C(104°F) • Load factor: Inverter rated current 80% 	
Indicate	Maintenance monitor	<ul style="list-style-type: none"> • Displays DC link bus voltage, Max. Output current in RMS, Input watt-hour, Input watt-hour data, Temperature (inside the inverter and heat sink, maximum value of heat sink), Capacitance of the DC link bus capacitor, Lifetime of DC link bus capacitor (elapsed hours and remaining hours), Cumulative run time (power-ON time counter of the inverter, electrolytic capacitors on the printed circuit boards, cooling fan and each motor), Remaining time before the next motor maintenance, Remaining startup times before the next maintenance, Number of startups (of each motor), Light alarm factors (Latest to 3rd last), Contents and numbers of RS-485 communications errors, Option error factors , Number of option errors, ROM version of the inverter, Keypad and Option port <ul style="list-style-type: none"> • Cumulative run time : Shows the content of the cumulative power-ON time counter of the inverter. Counter range : 0 to 65,535 hours Display : Upper 2 digits and lower 3 digits are displayed alternately. Example : 0 <-> 535h (535 hours) 5 <-> 535h (65,535 hours) The lower 3 digits are displayed with h (hour). When the count exceeds 65,535, the counter will be reset to "0" and start over again. • DC link bus voltage : Shows the DC link bus voltage of the inverter main circuit. • Max. temperature inside the inverter : Shows the maximum temperature inside the inverter for every hour. (Temperatures below 20°C(68°F) are displayed as 20°C(68°F).) • Max. temperature of heat sink : Shows the maximum temperature of the heat sink for every hour. (Temperatures below 20°C(68°F) are displayed as 20°C(68°F).) • Max. effective output current : Shows the maximum current in RMS for every hour. • Capacitance of the DC link bus capacitor : Shows the current capacitance of the DC link bus capacitor in %, based on the capacitance when shipping as 100%. <ul style="list-style-type: none"> • Cumulative run time of electrolytic capacitors on the printed circuit boards : Shows the content of the cumulative run time counter of the electrolytic capacitors on the printed circuit boards, which is calculated by multiplying the cumulative run time count by the coefficient based on the surrounding temperature condition. Counter range: 0 to 99,990 hours Display range: 0 to 9999 and the "x10" LED turns ON. Actual cumulative run time of electrolytic capacitors on the printed circuit boards (hours) = Displayed value × 10 When the count exceeds 99,990 the counter stops and the LED monitor sticks to 9999. • Cumulative run time of the cooling fan : Shows the content of the cumulative run time counter of the cooling fan. This counter does not work when the cooling fan ON/OFF control is enabled and the fan stops. • Number of startups : Shows the content of the motor startup counter (i.e., the number of run commands issued). Counter range: 0 to 65,530 times Display range: 0 to 9999 If the count exceeds 10,000, the x10 LED turns ON and the LED monitor shows one-tenth of the value. When the count exceeds 65,530, the counter will be reset to "0" and start over again. • Input watt-hour : Shows the input watt-hour of the inverter. Display range: 0.001 to 9999 Input watt-hour = Displayed value × 100 kWh To reset the integrated input watt-hour and its data, set function code E51 to "0.000." When the input watt-hour exceeds 999,900 kWh, the counter will be reset to "0." • Input watt-hour data : Shows the value expressed by "input watt-hour (kWh) × E51" (whose data range is 0.000 to 9,999). Unit: None.(Display range: 0.001 to 9999 . The data cannot exceed 9999. (It will be fixed at 9,999 once the calculated value exceeds 9999.)) Depending on the value of integrated input watt-hour data, the decimal point on the LED monitor shifts to show it within the LED monitor's resolution. To reset the integrated input watt-hour data, set function code E51 to "0.000." • Number of RS-485 communications errors (COM port 1) : Shows the total number of errors that have occurred in RS-485 communication (COM port 1, connection to keypad) after the power is turned ON. Once the count exceeds 9999, the counter will be reset to "0." • Content of RS-485 communications error (COM port 1) : Shows the latest error that has occurred in RS-485 communication (COM port 1) in decimal. • Number of option errors 1 : Shows the total number of errors that have occurred in the option. Once the count exceeds 9999, the counter will be reset to "0." 	

Common specifications

Items	Specifications	Remarks
Maintenance monitor	• Inverter's ROM version : Shows the inverter's ROM version as a 4-digit code.	
	• Keypad's ROM version : Shows the keypad's ROM version as a 4-digit code.	
	• Number of RS-485 communications errors (COM port 2) : Shows the total number of errors that have occurred in RS-485 communication (COM port 2, connection to terminal block) after the power is turned ON. Once the count exceeds 9999, the counter will be reset to "0."	
	• Content of RS-485 communications error (COM port 2) : Shows the latest error that has occurred in RS-485 communication (COM port 2, connection to terminal block) in decimal.	
	• Option ROM version 1 : Shows the ROM version as a 4-digit code. If the option has no ROM, "----" appears on the LED monitor.	
	• Cumulative motor run time : Shows the content of the cumulative power-ON time counter of motor. Counter range: 0 to 99,990 hours Display range: 0 to 9999 The x10 LED turns ON. Actual cumulative motor run time (hours) = Displayed value x 10 When the count exceeds 99,990, the counter will be reset to "0" and start over again.	
	• Temperature inside the inverter (Realtime value) : Shows the current temperature inside the inverter.	
	• Temperature of heat sink (Realtime value) : Shows the current temperature of the heat sink inside the inverter.	
	• Lifetime of DC link bus capacitor (Elapsed hours) : Shows the cumulative time during which a voltage is applied to the DC link bus capacitor. When the main power is shut down, the inverter automatically measures the discharging time of the DC link bus capacitor and corrects the elapsed time.	
	• Lifetime of DC link bus capacitor (Remaining hours) : Shows the remaining lifetime of the DC link bus capacitor, which is estimated by subtracting the elapsed time from the lifetime: 10 years - Type FRN0006F2E-4G□, FRN0011F2E-4G□ : 7years.	
	• Remaining time before the next maintenance : Shows the time remaining before the next maintenance, which is estimated by subtracting the cumulative run time of motor from the maintenance interval specified by H78. Display range: 0 to 9999 The x10 LED turns ON. Time remaining before the next maintenance (hour) = Displayed value x 10	
	• Remaining startup times before the next maintenance : Shows the startup times remaining before the next maintenance, which is estimated by subtracting the number of startups from the preset startup count for maintenance specified by H79	
	• Light alarm factor (Latest) : Shows the factor of the latest light alarm as an alarm code.	
	• Light alarm factor (Last) : Shows the factor of the last light alarm as an alarm code.	
	• Light alarm factor (2nd last) : Shows the factor of the 2nd last light alarm as an alarm code.	
• Light alarm factor (3rd last) : Shows the factor of the 3rd last light alarm as an alarm code.		
• Option error factor 1 : Shows the factor of the error that has occurred.		
I/O checking	Displays the I/O signal states of control circuit terminals using the segment ON/OFF of the 7-segment LED monitor or hexadecimal format. (digital and analog signals)	
	• I/O signals on the control circuit terminals : Shows the ON/OFF state of the digital I/O terminals.	
	• I/O signals on the control circuit terminals under communications control : Shows the ON/OFF state of the digital I/O terminals that received a command via RS-485 and field bus (option) communications.	
	• Input voltage on terminal [I2] : Shows the input voltage on terminal [I2] in volts (V).	
	• Input current on terminal [C1] : Shows the input current on terminal [C1] in milliamperes (mA).	
	• Output voltage on terminal [FM1] : Shows the output voltage on terminal [FM1] in volts (V).	
	• Output frequency on terminal [FM1] : Shows the output pulse rate per unit of time on terminal [FM1] in (p/s).	
	• Input voltage on terminal [V2] : Shows the input voltage on terminal [V2] in volts (V).	
	• Output current on terminal [FM1] : Shows the output current on terminal [FM1] in milliamperes (mA).	
	• Output voltage on terminal [FM2] : Shows the output voltage on terminal [FM2] in volts (V).	
	• Output current on terminal [FM2] : Shows the output current on terminal [FM2] in milliamperes (mA).	
	• Option control circuit terminal (I/O) : Shows the ON/OFF state of the output terminal on relay output interface cards (option).	
	• Terminal [X5] pulse input monitor : Shows the pulse rate of the pulse train signal on terminal [X5].	
	• PT detection temperature (Ch.1) : Shows the detection temperature of the PT option (Ch.1).	
	• PT detection temperature (Ch.2) : Shows the detection temperature of the PT option (Ch.2).	
	• Input voltage on terminal [32] : Shows the input voltage on terminal [32] on the analog interface card (option) in volts (V). (The AIO option card is required.)	
	• Input current on terminal [C2] : Shows the input current on terminal [C2] on the analog interface card (option) in milliamperes (mA). (The AIO option card is required.)	
	• Output voltage on terminal [AO] : Shows the output voltage on terminal [AO] on the analog interface card (option) in volts (V). (The AIO option card is required.)	
• Output current on terminal [CS] : Shows the output current on terminal [CS] on the analog interface card (option) in milliamperes (mA). (The AIO option card is required.)		
• Customizable logic timer monitor : Monitors the timer or counter value in the customizable logic specified by U91.		
Locked by password	• Limits to change or display in function code.	
Trip mode	• Displays the cause of trip by codes.	
Light-alarm	• Shows the light-alarm display L -RL .	
Running or trip mode	• Trip history: Saves and displays the cause of the last four trips (with a code). • Saves and displays the detailed operation status data of the last four trips	
Inverter loader	Personal computer software tool that supports the operation of the inverter via an RS-485 communications link.	
	• Setting of function code : Manage the function codes (list, edit, comparison, multi-monitor).	
	• Editing customizable logic : FRENIC Visual Customizer	
	• Running status monitor : I/O monitor, system monitor, alarm monitor, etc.	
	• Test-running : Remotely run or stop the inverter.	
	• Real-time trace : The real-time trace monitors (minimum sampling time : 20 to 200ms) up to 4 analog readouts and up to 8 digital ON/OFF signals to display the running status of a selected inverter in real-time waveforms	
• Historical trace : The historical trace monitors the running status of a selected inverter in greater detail with more contiguous waveforms than in the real-time trace. - Sampling time : 1 to 200ms - Up to 4 analog and 8 digital readouts (Maxmum) (Data store size : 2kB)		

*Note : The meaning of the described abbreviations are shown as follows. VF: V/f Control PM-SVC: Magnetic pole position sensorless vector control

Wiring diagram

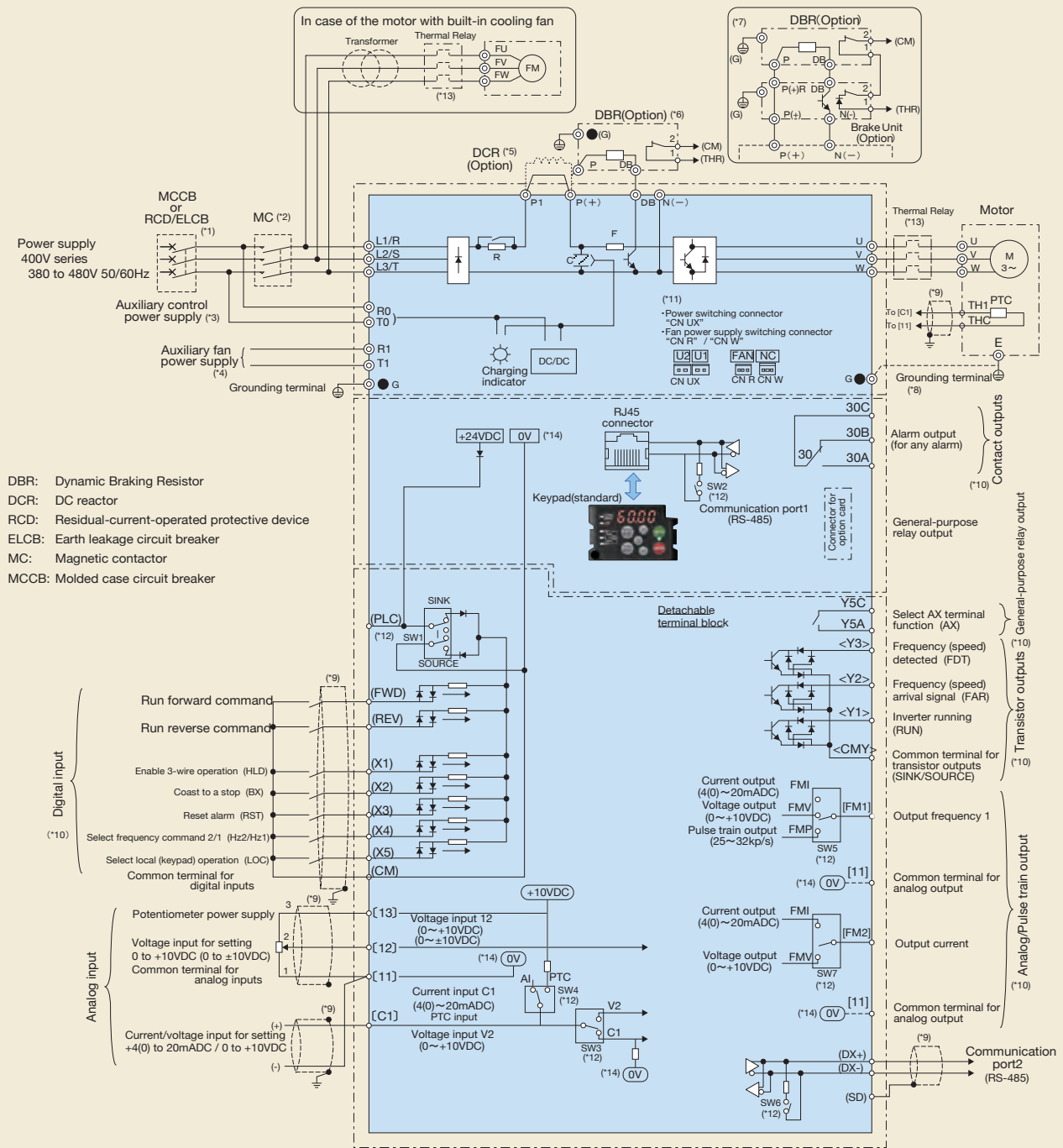

- *1 Install a recommended molded case circuit breaker (MCCB) or residual-current-operated protective device (RCD)/earth leakage circuit breaker (ELCB) (with overcurrent protection function) in the primary circuit of the inverter to protect wiring. Ensure that the circuit breaker capacity is equivalent to or lower than the recommended capacity.
- *2 Install a magnetic contactor (MC) for each inverter to separate the inverter from the power supply, apart from the MCCB or RCD/ELCB, when necessary. Connect a surge absorber in parallel when installing a coil such as the MC or solenoid near the inverter.
- *3 The R0 and T0 terminals are provided for inverters of type 0045 or above(400V class). To retain an alarm output signal ALM issued on inverter's programmable output terminals by the protective function or to keep the keypad alive even if the main power has shut down, connect these terminals to the power supply lines. Even if without connecting the power supply to these terminals, the inverter can run as long as connecting the power supply to the terminals L1/R, L2/S, L3/T.
- *4 Normally no need to be connected. Use these terminals when the inverter is equipped with a high power-factor, regenerative PWM converter (RHC series). (Type 0176 or above/400V only)
- *5 When connecting an optional DC reactor (DCR), remove the jumper bar from the terminals P1 and P(+). The type 0150 and higher types are sure to connect the DCR. Use a DCR when the capacity of the power supply transformer exceeds 500 kVA and is 10 times or more the inverter rated capacity, or when there are thyristor-driven loads in the same power supply line.
- *6 Inverters of type 0060 or below(400V class) have a built-in braking chopper, connect a braking resistor between the terminals P(+) and DB if needed.
- *7 For inverters of type 0075 or above (400V class), need to use a braking unit to connect the braking resistor in order to upgrade the braking capability of inverters. Be sure to connect the braking unit (option) to terminals P(+) and N(-). Auxiliary terminals [1] and [2] have polarity. Be sure to connect as this figure.
- *8 A grounding terminal for a motor. Use this terminal if needed.
- *9 For control signal wires, use twisted or shielded-twisted wires. When using shielded-twisted wires, connect the shield of them to the common terminals of the control circuit. To prevent malfunction due to noise, keep the control circuit wiring away from the main circuit wiring as far as possible (recommended: 10 cm(3.9 inches) or more). Never install them in the same wire duct. When crossing the control circuit wiring with the main circuit wiring, set them at right angles.
- *10 The connection diagram shows factory default functions assigned to digital input terminals [X1] to [X5], [FWD] and [REV], transistor output terminals [Y1] to [Y3], contact output terminals [Y5A/C] and [30A/B/C], and analog output terminals [FM1] and [FM2].
- *11 The power switching connectors (CN UX) and the fan power supply switching connectors (CN R and CN W) are for type 0176(400 V class) or above.
- *12 Slide switches on the control printed circuit board (control PCB). Use these switches to customize the inverter operations.
- *13 Use auxiliary contacts of the thermal relay (manually restorable) to trip the molded case circuit breaker (MCCB) or magnetic contactor (MC).
- *14 [OV] and (OV) are separated and insulated.

Outline drawing

Rated voltage	Nominal applied motor (kW)	Type	Degree of protection	Outside dimensions (mm)			Dwg.no.
				W (mm)	H (mm)	D (mm)	
3-phase 400V	0.75	FRN0002F2E-4G	IP20	110	130	162	Fig.A
	1.1	FRN0003F2E-4G				186	
	2.2	FRN0005F2E-4G		140	130	199	Fig.B
	3	FRN0006F2E-4G					
	5.5	FRN0011F2E-4G					
	7.5	FRN0018F2E-4G					
	11	FRN0023F2E-4G					
	15	FRN0031F2E-4G					
	18.5	FRN0038F2E-4G					
	22	FRN0045F2E-4G					
	30	FRN0060F2E-4G	IP00	250	400	195	Fig.E
	37	FRN0075F2E-4G					
	45	FRN0091F2E-4G		320	550	255	Fig.F
	55	FRN0112F2E-4G					
	75	FRN0150F2E-4G					
	90	FRN0176F2E-4G		355	615	270	Fig.G
	110	FRN0210F2E-4G			675		
	132	FRN0253F2E-4G		530	740	315	Fig.J
	160	FRN0304F2E-4G					
	200	FRN0377F2E-4G		530	1000	360	Fig.K
220	FRN0415F2E-4G						
280	FRN0520F2E-4G	680	1000	360	Fig.L		

Body

[Unit:mm]

Fig.A

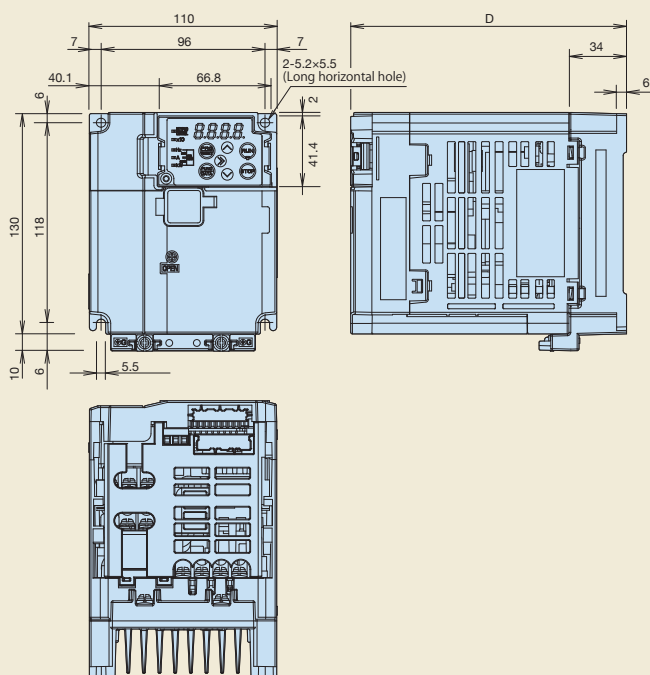
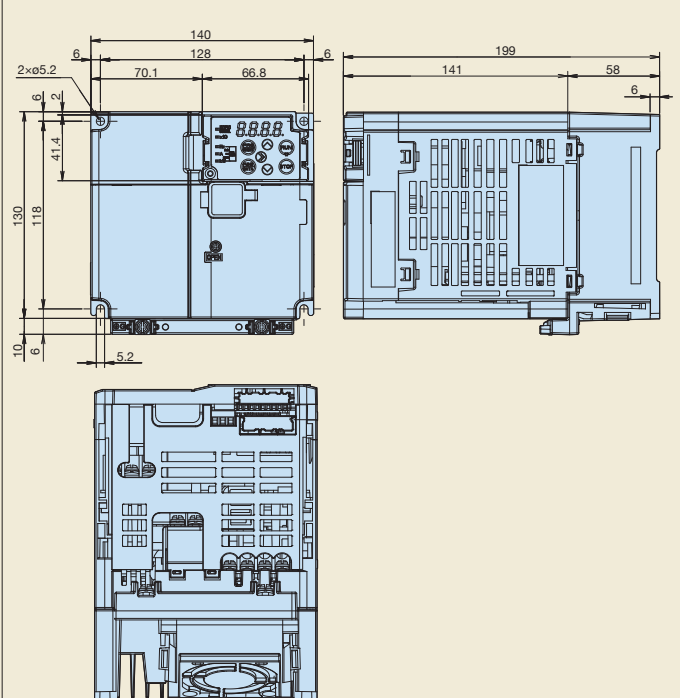

Fig.B



Outline drawing

Body

Fig.C

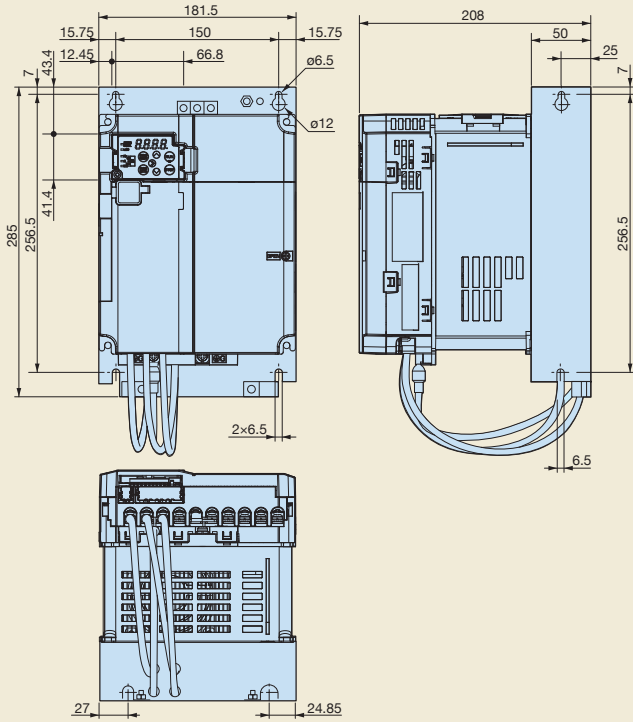

[Unit:mm]

Fig.D

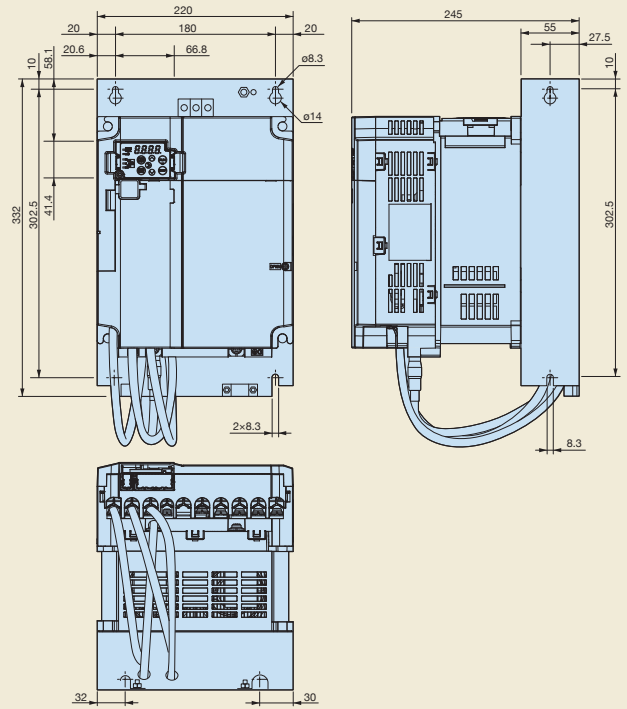

Body

Fig.E

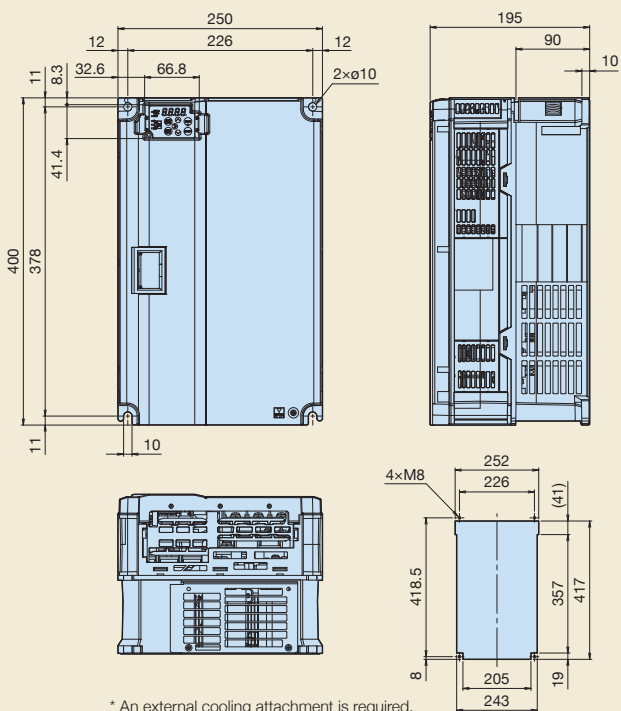

[Unit:mm]

Fig.F

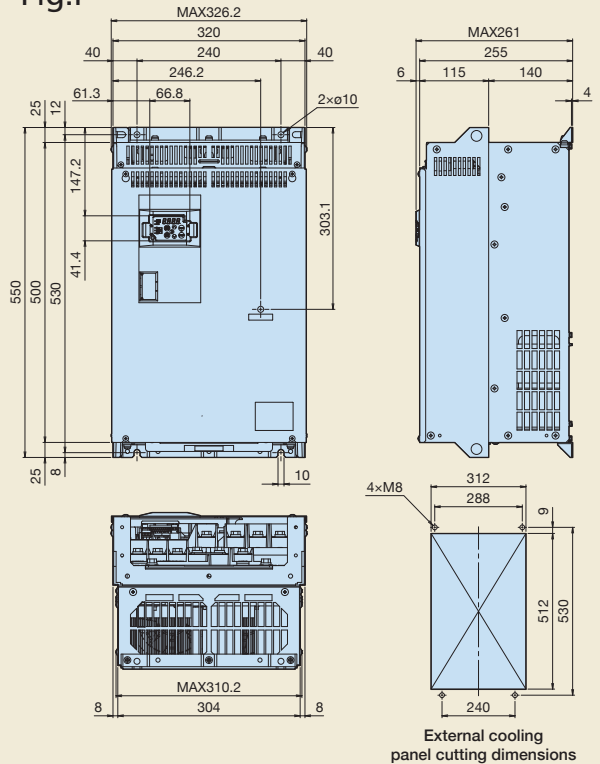

* An external cooling attachment is required.
Model: PB-F1-30

External cooling
panel cutting dimensions

Outline drawing

Body

[Unit:mm]

Fig.G

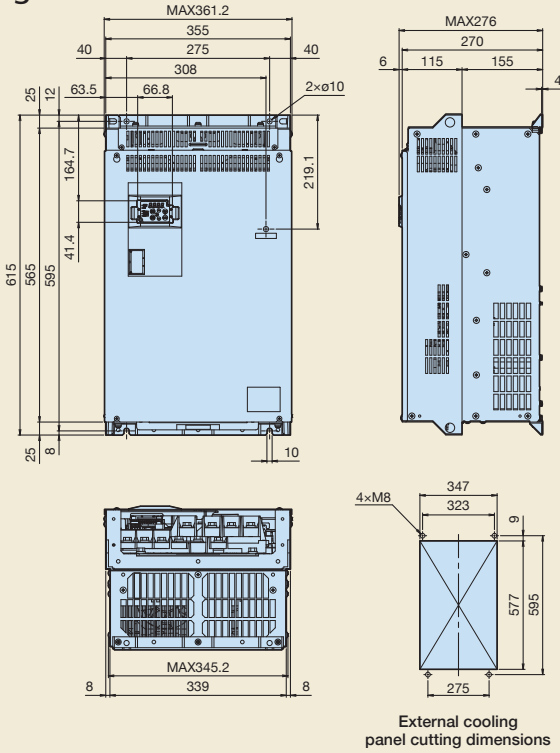
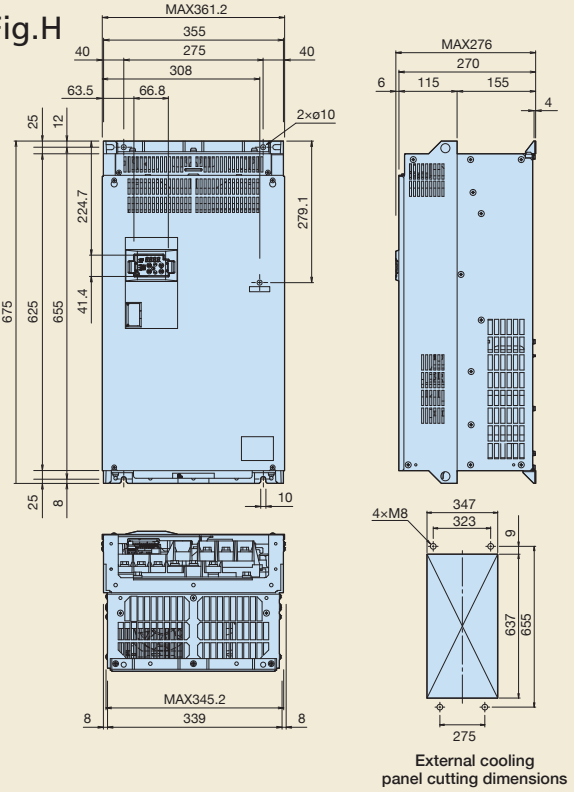

Fig.H



Body

[Unit:mm]

Fig.I

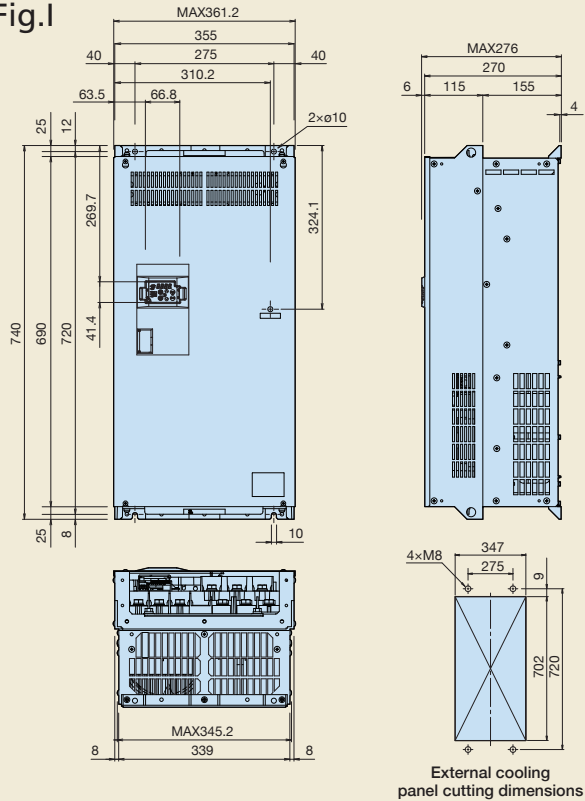
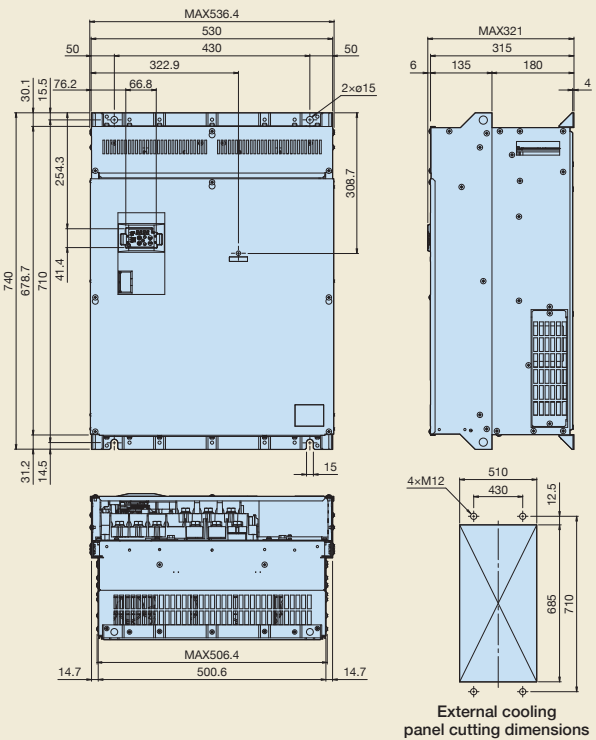

Fig.J



Options

Relay output interface card (OPC-F2-RY)*

This is an optional card that converts the transistor output at terminals Y1 to Y3 on the inverter body to relay output (1c). Each card has two relay outputs, and four relay outputs are available by installing two cards.

Note: When the card is mounted, the terminals Y1 to Y4 on the inverter body

Communications rate: 3 circuits built-in
Transmission distance: 1c
Connection connector: AC250V, 0.3A $\cos\phi = 0$.
 DC48V, 0.5A (Resistance load)

Analog input interface card (OPC-AIO)*

This card allows analog input and output to be used.

Analog input: 1 analog voltage input point (0~±10V)
 1 analog current input point (4~20mA)
Analog output: 1 analog voltage output point (0~±10V)
 1 analog current output point (4~20mA)

Resistance temperature detector input card (OPC-PT)*

This card can connect FRENIC-HVAC with a mountable two-channel resistance temperature detector (hereinafter-called RTD) to convert temperature values into digital values.

The following five types of mountable RTU are supported: JPt100, Pt100, Ni100, Pt1000, and Ni1000.

DeviceNet communications card (OPC-DEV)*

This card enables operation instruction and frequency command to be set from the DeviceNet master, allowing operation conditions to be monitored and all the function codes to be changed and checked.

No. of connection nodes: max. 64 units (including the master unit)
MAC ID: 0~63
Insulation: 500V DC (photocoupler insulation)
Communications rate: 500kbps/250kbps/125kbps
Network consumed power: max. 80mA, 24V DC

CC-Link communications card (OPC-CCL)*

By connecting this card with the CC-Link master unit, the communications rate up to 10Mbps can be supported and the transmission distance is covered up to 1200 m in total.

No. of connection units: 42 units
Communications method: CC-Link Ver1.10 and Ver2.0
Communications rate: 156kbps~

PROFIBUS-DP communications card (OPC-PDP3)*

This card enables operation instruction and frequency command to be set from the PROFIBUS-DP master, allowing operation conditions to be monitored and all the function codes to be changed and checked.

Communications rate: 9.6kbps~12Mbps
Transmission distance: ~1,200m
Connection connector: 2×6-pole terminal block

LonWorks communications card (OPC-LNW)*

This card allows peripheral equipment (including a master unit) that is connected via LonWorks to be connected with the inverter, enabling operation instruction and frequency command to be set from the master unit.

Mounting adapter for option card (OPC-E2-ADP1, OPC-E2-ADP2, OPC-E2-ADP3)

This adapter is used to equip inverters with communication and I/O interface option cards. The adapter used will differ depending on the capacity.

FRN0002F2E-4G to FRN0038F2E-4G: OPC-E2-ADP1
 FRN0045F2E-4G to FRN0060F2E-4G: OPC-E2-ADP2
 FRN0075F2E-4G to FRN0520F2E-4G: OPC-E2-ADP3

Multi-Function keypad (TP-A1-E2C)

- The regulator is indicated by enlarging the LCD.

1. Present value (PV)	5. Output current	9. Power consumption
2. Setting value (SV)	6. Output voltage	10. Cumulative energy
3. Manipulating value (MV)	7. Torque	
4. Frequency	8. Rotation speed	

*Possible to show understandable indications through the unit conversion function.

*Multi-language function: 19 languages + user customized language supported

Japanese, English, Chinese, German, French, Spanish, Italian, Russian, Greek, Turkish, Malay, Vietnamese, Thai, Indonesian, Polish, Czech, Swedish, Portuguese, Dutch

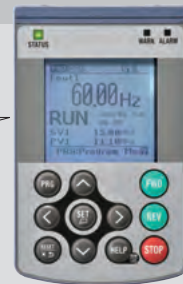

*Available by the combination use of the mounting adapter.



NOTES

When running general-purpose motors

• Driving a 400V general-purpose motor

When driving a 400V general-purpose motor with an inverter using extremely long cables, damage to the insulation of the motor may occur. Use an output circuit filter (OFL) if necessary after checking with the motor manufacturer. Fuji's motors do not require the use of output circuit filters because of their reinforced insulation.

• Torque characteristics and temperature rise

When the inverter is used to run a general-purpose motor, the temperature of the motor becomes higher than when it is operated using a commercial power supply. In the low-speed range, the cooling effect will be weakened, so decrease the output torque of the motor. If constant torque is required in the low-speed range, use a Fuji inverter motor or a motor equipped with an externally powered ventilating fan.

• Vibration

When the motor is mounted to a machine, resonance may be caused by the natural frequencies, including that of the machine. Operation of a 2-pole motor at 60Hz or more may cause abnormal vibration.

* Study use of tier coupling or dampening rubber.

* It is also recommended to use the inverter jump frequency control to avoid resonance points.

• Noise

When an inverter is used with a general-purpose motor, the motor noise level is higher than that with a commercial power supply. To reduce noise, raise carrier frequency of the inverter. High-speed operation at 60Hz or more can also result in more noise.

When running special motors

• Explosion-proof motors

When driving an explosion-proof motor with an inverter, use a combination of a motor and an inverter that has been approved in advance.

• Brake motors

For motors equipped with parallel-connected brakes, their braking power must be supplied from the primary circuit (commercial power supply). If the brake power is connected to the inverter power output circuit (secondary circuit) by mistake, problems may occur.

Do not use inverters for driving motors equipped with series-connected brakes.

• Geared motors

If the power transmission mechanism uses an oil-lubricated gearbox or speed changer/reducer, then continuous motor operation at low speed may cause poor lubrication. Avoid such operation.

• Single-phase motors

Single-phase motors are not suitable for inverter-driven variable speed operation. Use three-phase motors.

Environmental conditions

• Installation location

Use the inverter in a location with an ambient temperature range of -10 to 50°C.

The inverter and braking resistor surfaces become hot under certain operating conditions. Install the inverter on nonflammable material such as metal. Ensure that the installation location meets the environmental conditions specified in "Environment" in inverter specifications.

Combination with peripheral devices

• Installing a molded case circuit breaker (MCCB)

Install a recommended molded case circuit breaker (MCCB) or an earth leakage circuit breaker (ELCB) in the primary circuit of each inverter to protect the wiring. Ensure that the circuit breaker capacity is equivalent to or lower than the recommended capacity.

• Installing a magnetic contactor (MC) in the output (secondary) circuit

If a magnetic contactor (MC) is mounted in the inverter's secondary circuit for switching the motor to commercial power or for any other purpose, ensure that both the inverter and the motor are fully stopped before you turn the MC on or off. Remove the surge killer integrated with the MC.

• Installing a magnetic contactor (MC) in the input (primary) circuit

Do not turn the magnetic contactor (MC) in the primary circuit on or off more than once an hour as an inverter fault may result. If frequent starts or stops are required during motor operation, use FWD/REV signals.

• Protecting the motor

The electronic thermal facility of the inverter can protect the general-purpose motor. The operation level and the motor type (general-purpose motor, inverter motor) should be set. For high-speed motors or water-cooled motors, set a small value for the thermal time constant to protect the motor.

If you connect the motor thermal relay to the motor with a long cable, a high-frequency current may flow into the wiring stray capacitance. This may cause the relay to trip at a current lower than the set value for the thermal relay. If this happens, lower the carrier frequency or use the output circuit filter (OFL).

• Discontinuance of power-factor correcting capacitor

Do not mount power factor correcting capacitors in the inverter (primary) circuit. (Use the DC REACTOR to improve the inverter power factor.) Do not use power factor correcting capacitors in the inverter output circuit (secondary). An overcurrent trip will occur, disabling motor operation.

• Discontinuance of surge killer

Do not mount surge killers in the inverter output (secondary) circuit.

• Reducing noise

Use of a filter and shielded wires are typical measures against noise to ensure that EMC Directives are met.

• Measures against surge currents

If an overvoltage trip occurs while the inverter is stopped or operated under a light load, it is assumed that the surge current is generated by open/close of the phase-advancing capacitor in the power system.

We recommend connecting a DC REACTOR to the inverter.

• Megger test

When checking the insulation resistance of the inverter, use a 500V megger and follow the instructions contained in the Instruction Manual.

Wiring

• Wiring distance of control circuit

When performing remote operation, use the twisted shield wire and limit the distance between the inverter and the control box to 20m.

• Wiring length between inverter and motor

If long wiring is used between the inverter and the motor, the inverter will overheat or trip as a result of overcurrent (high-frequency current flowing into the stray capacitance) in the wires connected to the phases. Ensure that the wiring is shorter than 50m. If this length must be exceeded, lower the carrier frequency or mount an output circuit filter (OFL).

When wiring is longer than 50m, and sensorless vector control or vector control with speed sensor is selected, execute off-line tuning.

• Wiring size

Select cables with a sufficient capacity by referring to the current value or recommended wire size.

• Wiring type

Do not use multicore cables that are normally used for connecting several inverters and motors.

• Grounding

Securely ground the inverter using the grounding terminal.

Selecting inverter capacity

• Driving general-purpose motor

Select an inverter according to the applicable motor ratings listed in the standard specifications table for the inverter. When high starting torque is required or quick acceleration or deceleration is required, select an inverter with a capacity one size greater than the standard.

• Driving special motors

Select an inverter that meets the following condition: Inverter rated current > Motor rated current.

Transportation and storage

When transporting or storing inverters, follow the procedures and select locations that meet the environmental conditions that agree with the inverter specifications.

 **Memo**

**Fuji Electric Asia Pacific Pte Ltd**

151 Lorong Chuan #02-01A New Tech Park
Singapore 556741
Tel: +65 65330014

Fuji Electric India Pvt. Ltd.

409 410, Meadows, Sahar Plaza,
Andheri Kurla Road,
J.B. Nagar, Andheri (E) Mumbai 400 059, India
Tel: +91-22-4010 4870

Fuji Electric Thailand Co.,Ltd

43 Thai CC Tower, 11th Fl., Room No. 114-6,
South Sathorn Road, Yannawa, Sathorn,
Bangkok 10120, Thailand
Tel: +66-2210-0615

PT. Fuji Electric Indonesia

Gedung Sucaco 2nd Floor,
Kebon Sirih Raya No.71 PO Box 4872,
Kebon Sirih, Jakarta Pusat,
10340, INDONESIA
Tel: +62 21 398-43211

Fuji Electric Vietnam Co.,Ltd

Room 401, 4th floor, Corner Stone Building,
16 Phan Chu Trinh, Hoan Kiem,
Ha Noi, VIETNAM
Tel: +84-4-3935-1593

Fuji Electric Co., Ltd.

Gate City Ohsaki, East Tower, 11-2,
Osaki 1-chome, Shinagawa-ku,
Tokyo 141-0032, Japan
Tel: +81-3-5435-7058
Fac: +81-3-5435-7420
www.fujielectric.com