

# Servo System ALPHA7S

“Strong” motor with “Speedy” response maximizes productivity!



# Dramatically evolved control functions significantly increase productivity

High-tech industrial equipment continues to evolve non-stop. To gain the maximum advantage of over other equipment, a servo system with high responsiveness and high precision is essential. With its dramatically evolved control functions, Fuji Servo System ALPHA7S raises the speed and precision of drive control to the highest level in the industry. It supports a broad range of monitoring functions and has reached the next level of safety. It meets the highest level of customer requirements for productivity improvement, cost reduction, and safety.



Speed and Frequency Response

3.2 kHz

Speedy response realizes ultra-high-speed control



INC/ABS

24 bit (16777216 pulses)

Fine resolution encoder further raises the precision of control



# Fuji Servo System

# ALPHA7S

Features .....	2
Model Codes .....	16
Servo Amplifier Specifications .....	17
Connection Diagram for Reference.....	20
Servomotor Specifications .....	22
External Dimensions.....	27
Options and Peripheral Equipment .....	35
Model List .....	38
Product Warranty.....	45

Servo Amplifier



# High-speed and high-precision control is realized by a basic performance that is at the highest level in the industry



## Speed and frequency response at 3.2kHz realizes ultra-high-speed control

Fuji's proprietary control algorithm achieves a speed and frequency response at 3.2kHz, the highest level in the industry. This reduces the tact time, enabling high-speed control.

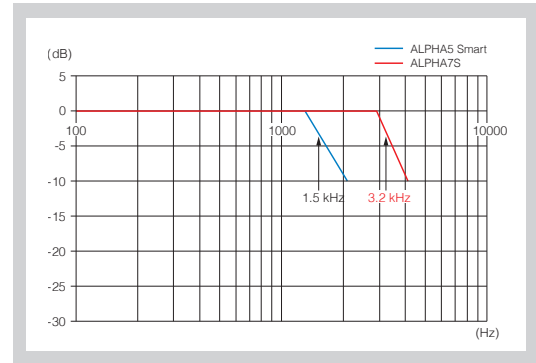



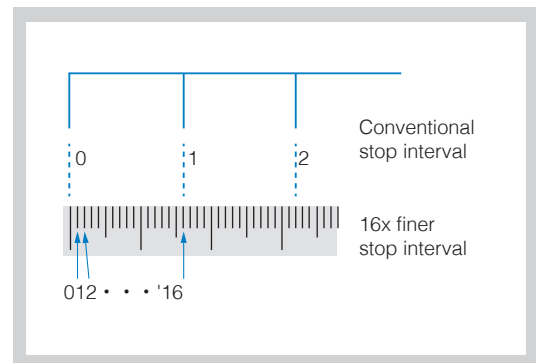

## The 24-bit fine resolution INC/ABS encoder significantly improves the precision of control

The encoder resolution is now as high as 24 bits. This provides much higher control precision than before, enabling high-precision control.



# Lineup of Products That Constitute an ALPHA7S System



## I Servomotor

Model		Rated speed (Max. speed)	Power supply	Rated output	Servomotor type		Protective construction	Encoder	Type
					Without brake	With brake			
GYSmotor Ultra-low Inertia		3000 r/min (0.75 kW or less: 6000 r/min 1.0 kW or more: 5000 r/min)	200 V series	8 types 0.05 to 2.0 kW	●	●	IP67 <sup>*1</sup>	24-bit ABS	GYS***D7-EB2(-B)
								24-bit INC	GYS***D7-NB2(-B)
GYB motor Medium Inertia		3000 r/min (6000 r/min)	200 V series	5 types 0.05 to 0.75 kW	●	●	IP67 <sup>*1</sup>	24-bit ABS	GYB***D7-EB2(-B/-C/-D)
								24-bit INC	GYB***D7-NB2(-B/-C/-D)
GYE motor Medium Inertia		3000 r/min (6000 r/min)	200 V series	3 types 0.2 to 0.75 kW	●		IP67 <sup>*1</sup>	17bit INC <sup>*2</sup>	GYE***D6-GC2
GYL motor Medium Inertia		1500 r/min (3000 r/min)	200 V series	5 types 0.85 to 4.4 kW	●	●	IP67 <sup>*1</sup>	17bit ABS	GYL***B6-PG2(-B)
								17bit INC	GYL***B6-TG2(-B)

\*1 Excludes shaft through-hole. (also excludes connectors for GYS motors of 0.75kW or lower, GYB motors of lead wire type, and GYE motors).

\*2 Magnetic encoder

## I Servo Amplifier

Model		Command interface	Control mode				Power supply	Capacity	Type	Applicable motor series
			Positioning function	Position	Speed	Torque				
	VVS type	General-purpose (Pulse/analog/ positioning/ Modbus)	●	●	●	●	Single-phase or 3-phase 200 to 240 VAC	0.05 to 0.75 kW	RYT***S7-VVS2	GYS GYB GYE GYL
							3-phase 200 to 240 VAC	0.85 to 4.4 kW		
	VCS type	EtherCAT		●	●	●	Single-phase or 3-phase 200 to 240 VAC	0.05 to 0.75 kW	RYT***S7-VCS2	GYS GYB GYE GYL
							3-phase 200 to 240 VAC	0.85 to 4.4 kW		

Features  
Model Codes  
Servo Amplifier Specifications  
Connection Diagram for Reference  
Servomotor Specifications  
External Dimensions  
Options and Peripheral Equipment  
Model List  
Product Warranty

# ALPHA7S Combination Table (GYS, GYB, GYE, GYL)

Applicable motor	Applicable motor capacity	GYS motor Ultra-low inertia 3000 [r/min] Brake: Without (with)	GYB motor Medium inertia 3000 [r/min] Brake: Without (with)	GYE motor Medium inertia 3000 [r/min] Brake: Without	GYL motor Medium inertia 1500 [r/min] Brake: Without (with)	
<b>Frame 1</b> RYT101S7-□□□2 RYT201S7-□□□2 RYT401S7-□□□2	0.05 kW	□40 GYS500D7-□□□2(-B)	□40 GYB500D7-□□□2(-B)			
	0.1 kW	GYS101D7-□□□2(-B)	GYB101D7-□□□2(-B)			
	0.05 kW	□40 GYS500D7-□□□2(-B)	□40 GYB500D7-□□□2(-B)			
	0.1 kW	GYS101D7-□□□2(-B)	GYB101D7-□□□2(-B)			
	0.2 kW	□60 GYS201D7-□□□2(-B)	□60 GYB201D7-□□□2(-B)	□60 GYE201D6-GC2		
	0.05 kW	□40 GYS500D7-□□□2(-B)	□40 GYB500D7-□□□2(-B)			
	0.1 kW	GYS101D7-□□□2(-B)	GYB101D7-□□□2(-B)			
	0.2 kW	□60 GYS201D7-□□□2(-B)	□60 GYB201D7-□□□2(-B)	□60 GYE201D6-GC2		
	0.4 kW	□60 GYS401D7-□□□2(-B)	□60 GYB401D7-□□□2(-B)	□60 GYE401D6-GC2		
	<b>Frame 2a</b> RYT751S7-□□□2	0.75 kW	□80 GYS751D7-□□□2(-B)	□80 GYB751D7-□□□2(-B)	□80 GYE751D6-GC2	
		<b>Frame 2b</b> RYT851S7-□□□2 RYT132S7-□□□2	0.85 kW			
	1.0 kW		□100 GYS102D7-□□□2(-B)			
1.3 kW						GYL132B6-□□□2(-B)
<b>Frame 3</b> RYT182S7-□□□2	1.5 kW	GYS152D7-□□□2(-B)				
	1.8 kW					GYL182B6-□□□2(-B)
<b>Frame 4</b> RYT292S7-□□□2 RYT442S7-□□□2	2.0 kW	GYS202D7-□□□2(-B)				
	2.4 kW					□180 GYL292B6-□□□2(-B)
	2.9 kW					GYL442B6-□□□2(-B)
	4.4 kW					

## General-purpose interface ALPHA7S VVS Type

- A single unit allows - Positioning run (immediate data operation) based on Modbus-RTU  
 - Positioning run (with 50 positioning data points) based on Di/Do signals  
 - Position, speed, and torque control run based on pulse train/analog input

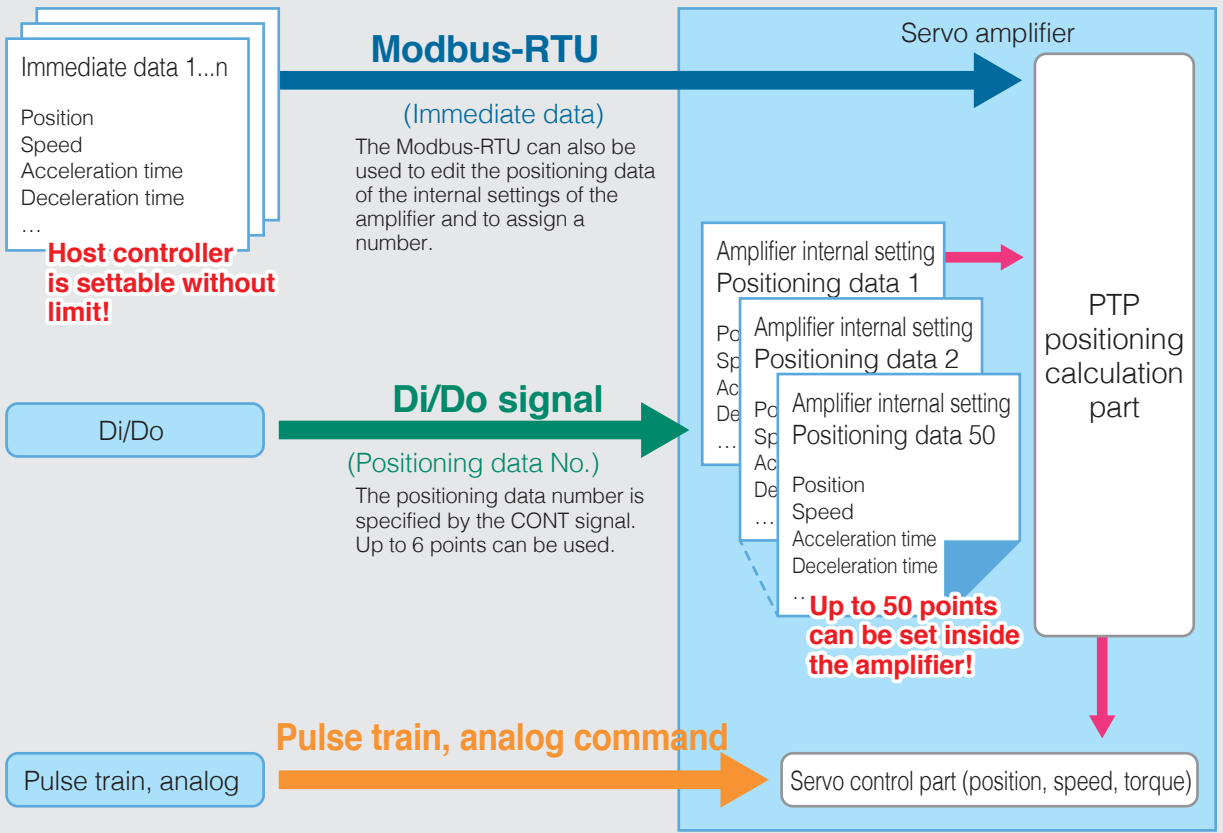

## Open network (with support for EtherCAT) ALPHA7S VCS Type

Device profile	CoE (Can application over EtherCAT)
Supported control mode	pp, pv, hm, csp, csv, cst, tq, ip
Synchronous mode	DC (synchronous), SM2 (synchronous), FreeRUN (asynchronous)
Minimum cycle time	125 μs

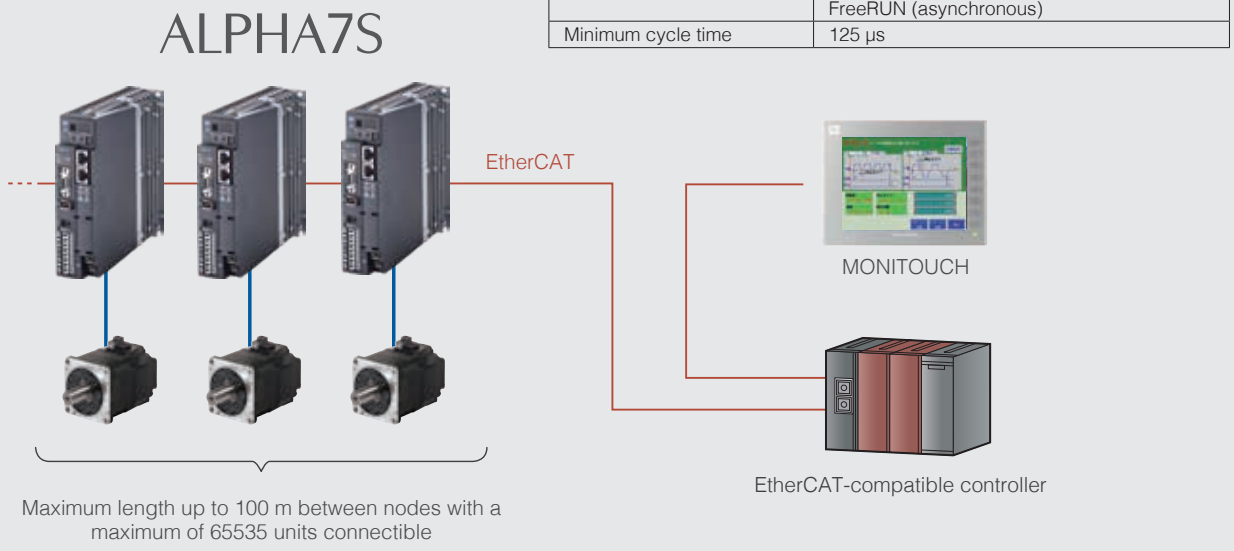

# Build and tune your system more easily and speedily

## Maximize performance by using in combination with MICREX-SX

### Scalable motion systems

When combining the servo with the EtherCAT-compatible SPH5000EC, users can build small- to large-scale (high-speed, high-accuracy) motion systems. By combining a single SPH5000EC, a motion control system with ALPHA7S VCSs can connect up to 64 axes to perform high-speed motion control for PTP positioning and synchronous control: 32 axes at a control cycle of 1 ms and 64 axes at 2 ms.

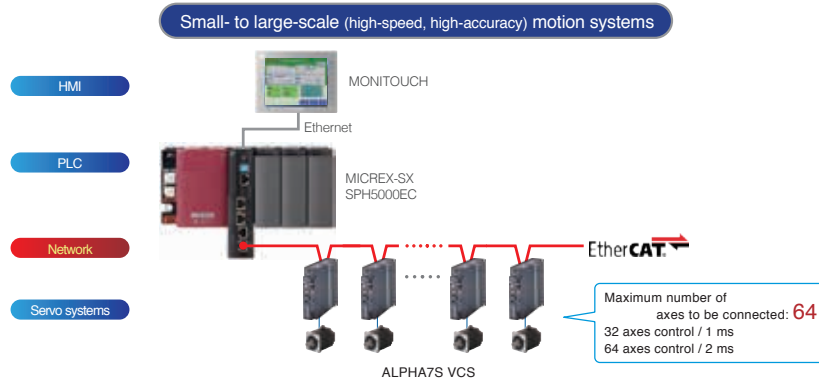

### A single CPU performs both sequence and motion control

Adding a single unit of MICREX-SX eliminates the need of a module dedicated to motion control, thus significantly reducing the initial cost. Also, work efficiency is dramatically improved by supporting both sequence and motion with a single programming tool\*.

\*SX-Programmer Expert (D300win)

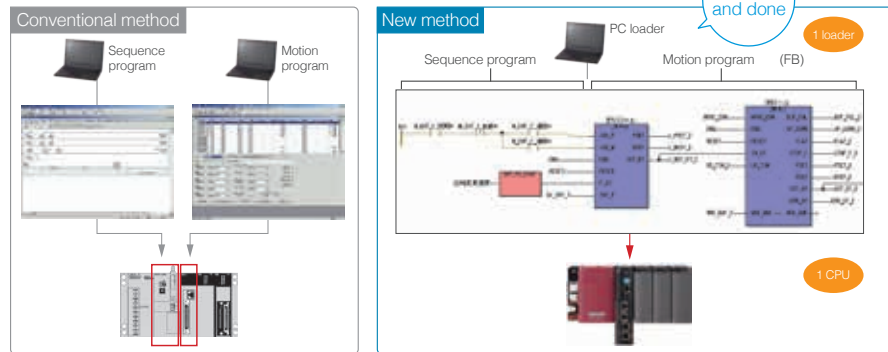

### Directly connectible with a single EtherCAT and easy to wire and extend

Just a single Ethernet cable completes the connection between the controller and servo. When you add an additional control axis to allow for the extension of the machine, you can connect it in a one-touch fashion using an Ethernet cable.

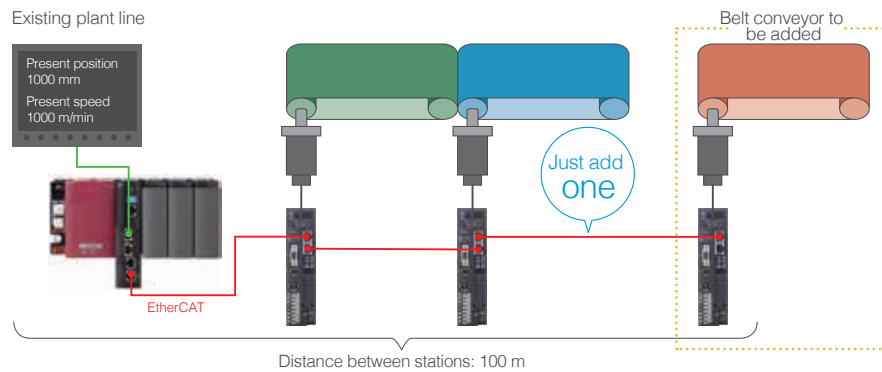

### Broad range of functional software "FBs" raises development efficiency

Various software parts, FBs (function blocks), are available free of charge. By appropriately combining FBs, you can build a motion program for a large-scale system in a short time. If you have trouble in developing programs, consult Fuji for support.

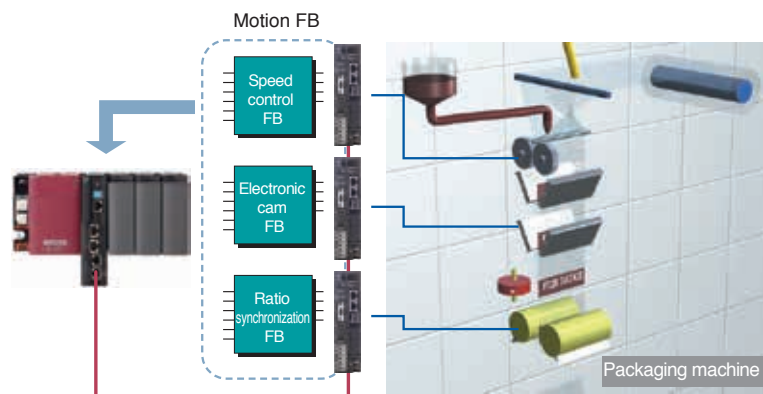

## Various features that allow standalone use of ALPHA7S

### PC loader tuning allows easy semi-automatic adjustment

#### Automatic servo adjustment in tuningless mode

In tuningless mode, you do not have to manually adjust the responsiveness (gain) because the servo system automatically does so. You no longer spend time on tuning at start-up time.

#### Finer adjustment is possible in auto tuning mode

In auto tuning mode, the servo amplifier automatically adjust the responsiveness (gain). This mode allows finer control than tuningless mode.

#### Highest precision requirements can be achieved in manual tuning mode

This mode is intended for use with machines that require high precision. It allows you to optimize multiple parameters at once, enabling high responsiveness (gain) adjustment.

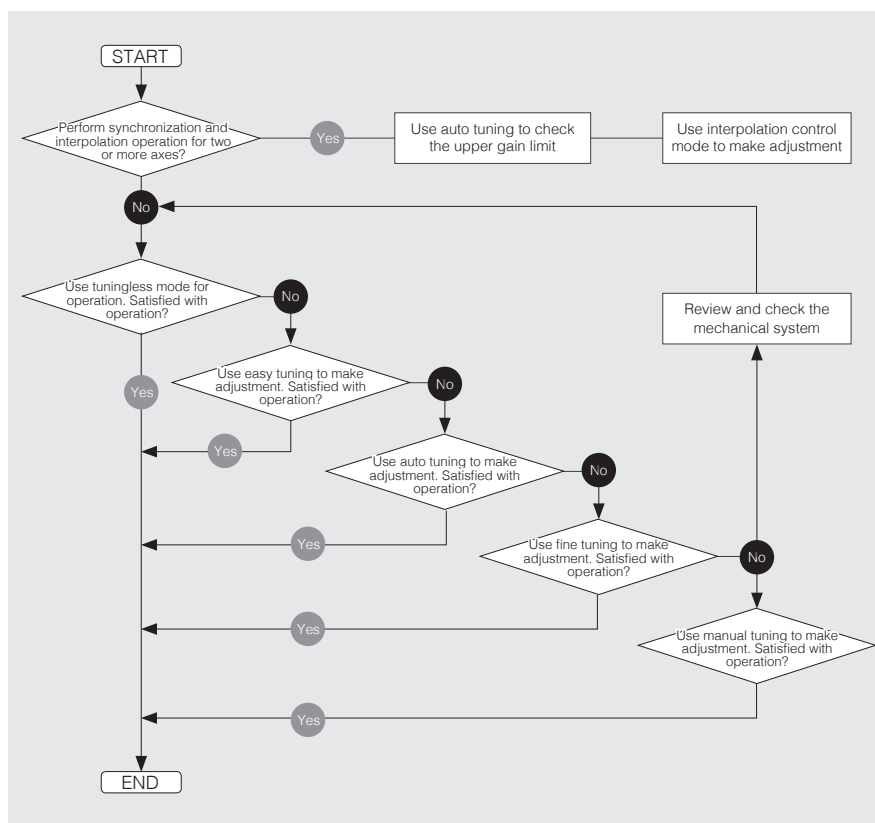

### Features that reduce the time required to set up a newly introduced machine

#### Test-run the machine before completion of a program using the pattern run feature

You can adjust the machine and servo before completion of a program for the controller.

#### Test-run a program before completion of the machine using sequence mode

You can run a controller program before completion of the machine, so you can debug programs more efficiently.

### Simplify your system using the built-in programmable positioning feature (applicable to the ALPHA7S VVS type only)

You can easily perform positioning run, using pre-registered positioning data. You can register positioning data for up to 50 points in the ALPHA7S VVS type. You can run the system by just selecting a program number and issuing a start command from the host controller. This feature is most useful for the purposes of inching and repetitive operations.

# Evolved control functions contribute to streamlining of operation and stabilization of quality

## New damping control suppresses the vibration at equipment edges

The introduction of a new control algorithm reduces the vibration at the edges of the equipment to one tenth, compared with the conventional damping control (used in our products). Support for models with three inertia systems makes it possible to control low-frequency vibrations at two points concurrently.

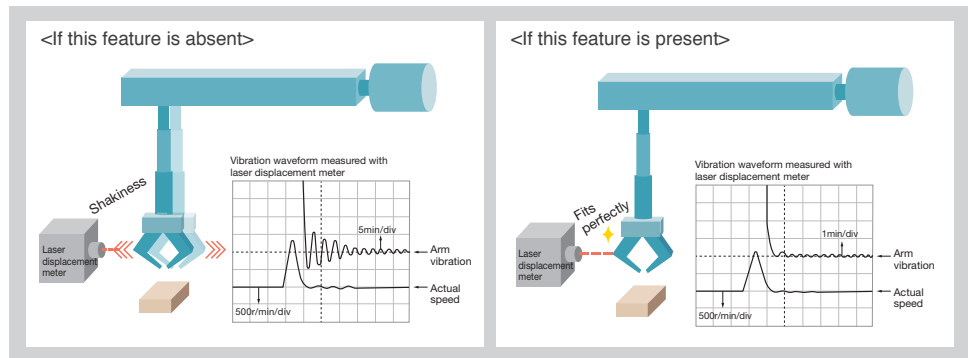

## The interference detection feature detects a collision, etc. and prevents breakage

The servo amplifier detects interference on the equipment (such as a collision with an edge of the machine) and operates to mitigate the shock to the machine when a collision occurs. This feature helps prevent damage to the equipment and reduce load on it.

\*Protection may not be complete depending on the operation type.

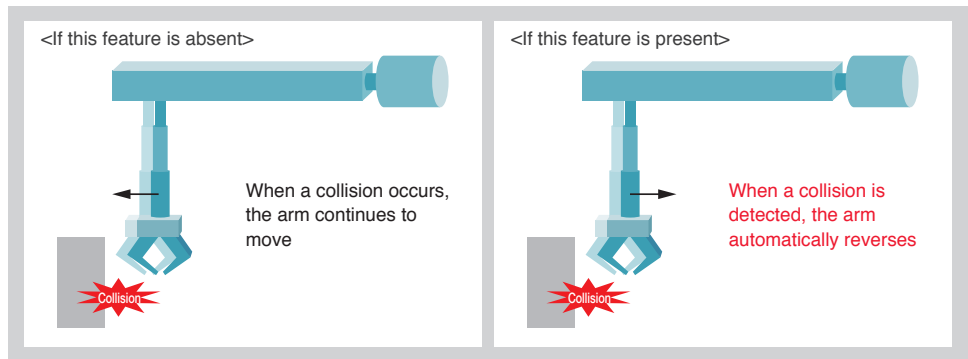

## The cogging feature ensures smooth operation

Since interference due to cogging of the servomotor is detected and compensated, speed ripples due to cogging can be reduced and smooth operation can be ensured even if the equipment does not support the increase of the speed loop gain.

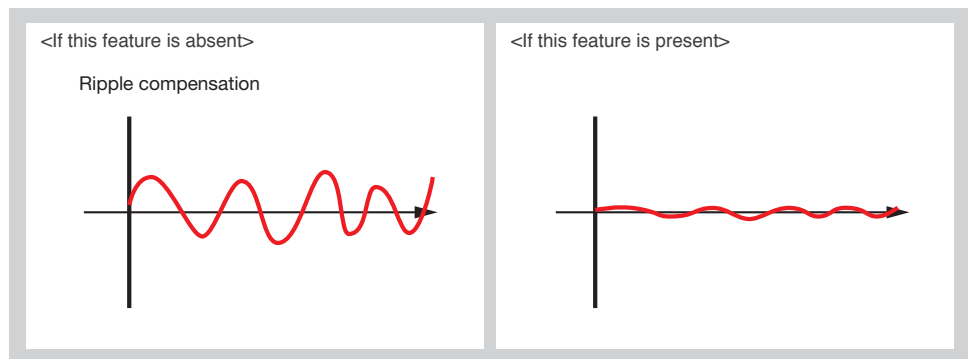

## Maximum input pulse frequency of 4 MHz

The system can support input frequencies from the host controller until the maximum frequency of 4 MHz is reached.

This allows a finer amount of travel per pulse, thus enabling positioning operation at a higher precision than before.

- Differential input: Max. input frequency  $\leq 4.0$  [MHz]
- Open collector input: Max. input frequency  $\leq 200$  [kHz]

## The notch filter feature suppresses the resonance of the machine

Now five notch filters are incorporated instead of two, further improving the machine resonance suppression feature.

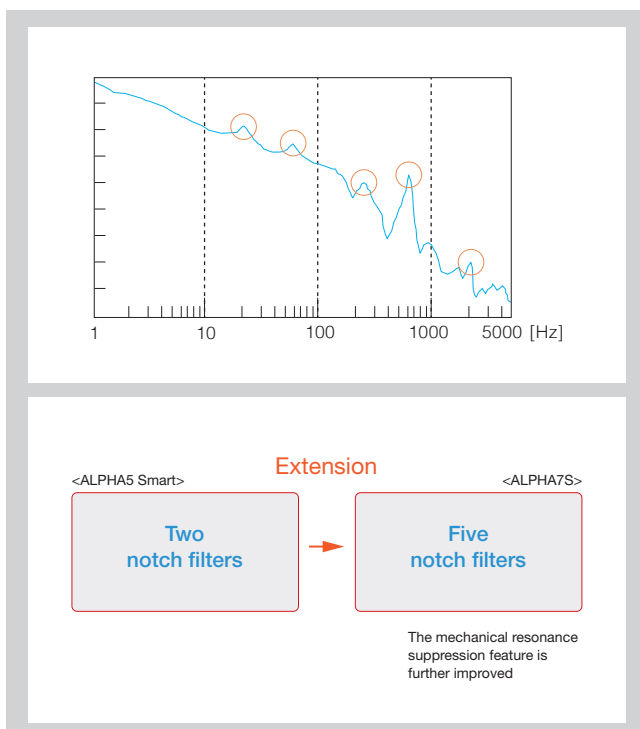

## The motor status can be monitored from the host controller

The system detects machine resonance and automatically configures the notch filters. While the auto notch filter feature is on, the system constantly performs detection and calculation, thus being able to respond even to moment-to-moment changes in resonant frequency.

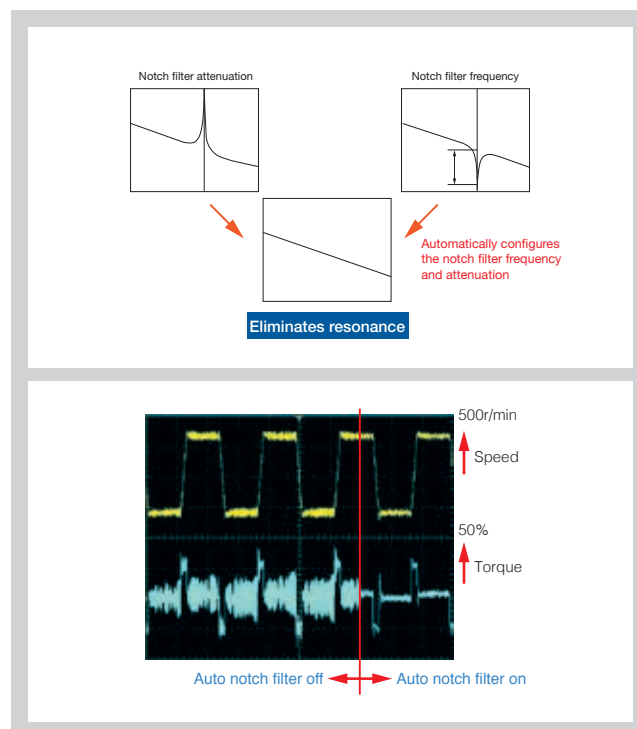

## One of three motor stop methods can be selected

You can select "rapid deceleration stop", "DB stop", or "coast-to-stop" when an alarm occurs, when the main power is off, or when the servo-on signal is off. Since limiting output torque at desired value is possible even if rapid deceleration stop is selected, impact shock to the machine can be reduced.\*

\* However, it is enabled when the control power supply is input.

## A homing program can be easily configured

Several homing features allow simple configuration by just combining servo parameters.

## Interrupt positioning feature

A fixed amount of movement is possible after detecting the mark signal, thereby enabling highly accurate mark operation. It can be used for positioning operation by detecting the mark signal of the material, or for stopping after moving a certain amount in the last stage when there is wobble or slippage in the mechanical system.

# Design and features that reduce the labor of maintenance

## Easily analyze the cause of alarm occurrence

When an alarm occurs, the system displays the content of the alarm as well as related data such as the speed and torque at the time of alarm occurrence. This allows you to accurately analyze the cause of the alarm.

## Life prediction and preventive maintenance features

You can check the status of the servomotor from the controller, so you can perform maintenance at the appropriate time. In addition, the system predicts the life for the following consumables and sends the data to the host controller for proactive failure prevention.

Battery

Main circuit capacitor

Cooling fan

## Long life design of servo amplifier parts

The design life of long-life parts has been further extended: 10 years for electrolytic capacitors and cooling fans. In addition, the design life of the battery is approximately 35,000 hours. (Retention time with the power supply shut off)

- \* The use conditions are as follows.
- Ambient temperature: 30°C (annual average)
  - Load factor: Up to 80%
  - Rate of operation: Up to 20 hours/day

## The environmentally resistant servomotor can be used in an environment with exposure to water and dust

The servomotor is by default compliant with IP67\* defined by the International Electrotechnical Commission (IEC). It has Class 6 dust resistance and Class 7 water resistance, which means that it can be used in an environment with exposure to water and dust.

- \* Excludes shaft through-hole (also excludes connectors for GYS and GYB motors of lead wire type).

# Space-saving design that allows installation in a small space

## Most compact in the industry\*. Further miniaturized servomotor

The overall length of the servomotor has been reduced by approximately 15 mm, compared with our existing products. This is the most advanced miniaturization in the industry.

- \* As of February 2017, for the GYB motor

## Compact servo amplifier that can be mounted in close contact

The servo amplifier is reduced in width by 5 mm and in footprint area by approximately 12% when compared with our conventional model\*. It can be mounted in close contact, allowing the reduction of the space required to mount it on the control panel of the machine.



- \* When mounted in close contact, 80% ED rating applies. There is no restriction when installed at spacings of 5 mm or greater.

- \* Comparison value with frame 1.

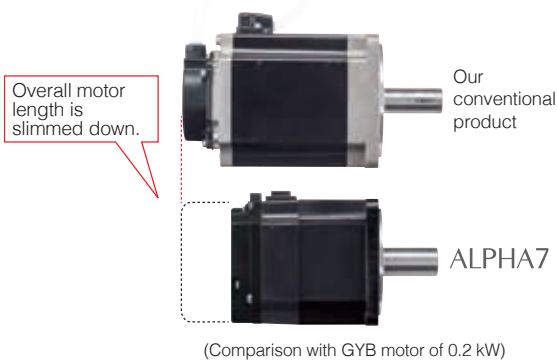

# Compatibility

## Compatible with ALPHA5 motors

ALPHA7S Series servo amplifiers can also power ALPHA5 Series motors (GYS5). For details on ALPHA5 Series motors, refer to "ALPHA5 Catalog 24C-1-J-0037".

## Parameter file conversion tool

The parameter files used in the ALPHA5 Smart Series can be automatically converted to ALPHA7S parameters. The parameter file conversion tool is bundled with the ALPHA7 loader software. The ALPHA7 loader software is available for free and can be downloaded from the Download Documents.

# Support for various standards is provided by default to allow for overseas business expansion

## Compliance with overseas standards and laws

The ALPHA7S Series supports international standards.

Standards and laws		Servo Amplifier	Servomotor
		ALPHA7S	
CE mark	Low voltage directive	EN61800-5-1	
	EMC directive	EN61800-3	
	Rotary electric machine	Not applicable	EN60034-1, EN60034-5
UL standards		UL61800-5-1	UL1004
China Compulsory Certificate (CCC) system		Not applicable	
Korea Radio Act (KC)		Compliant	Not applicable

<Certification mark>



CE: Compliant with EU (European Union) standards

UL: Compliant with the U.S. safety standards

cUL: Certifies the compliance of UL with CSA (Canada safety standards)

KC: Korea's nationally integrated certification mark

## By default compliant with RoHS

Environmentally-friendly design compliant with the 10 hazardous substances<sup>\*1</sup> of RoHS (EU's Restriction of Hazardous Substances) and six hazardous substances<sup>\*2</sup> of China RoHS (Management Methods for Controlling Pollution by Electronic Information Products).



\*1. Lead, mercury, cadmium, hexavalent chromium, polybrominated biphenyl (PBB), polybrominated diphenyl ether (PBDE), di-2 ethylhexyl phthalate (DEHP), butyl benzyl phthalate (BBP), di-n-butyl phthalate (DBP), diisobutyl phthalate (DIBP)

\*2 Lead, mercury, cadmium, hexavalent chromium, polybrominated biphenyl (PBB), polybrominated diphenyl ether (PBDE)

## Harmonic suppression

All models of servo amplifiers used by specific consumers are subject to the "Japanese Guideline for Suppressing Harmonics by Customers Receiving High Voltage or Special High Voltage". All users required to apply guidelines must calculate equivalent capacity as well as harmonic outflow current based on these guidelines, and take appropriate measures if the calculated harmonic current exceeds the limit stipulated for the contracted wattage.

Circuit classification	Circuit type	Reactor	Conversion factor
3	Three-phase bridge (capacitor smoothing)	None	3.4
		Yes (AC side)	1.8
		Yes (DC side)	1.8
		Yes (AC side, DC side)	1.4
4	Single-phase bridge (capacitor smoothing)	None	2.9
		Yes (AC side)	1.3

For information on how to calculate the harmonic current, use the following as a reference.

Reference material: Japan Electrical Manufacturers' Association

- Pamphlet "About Servo Amplifier Harmonic Suppression"

- JEM-TR225 "Servo Amplifier Harmonic Current Calculation Method for Specific Consumers"

Fuji offers optimum solutions according to customer needs.

## 01 Prober

Inspecting instrument used in semi-conductor manufacturing equipment

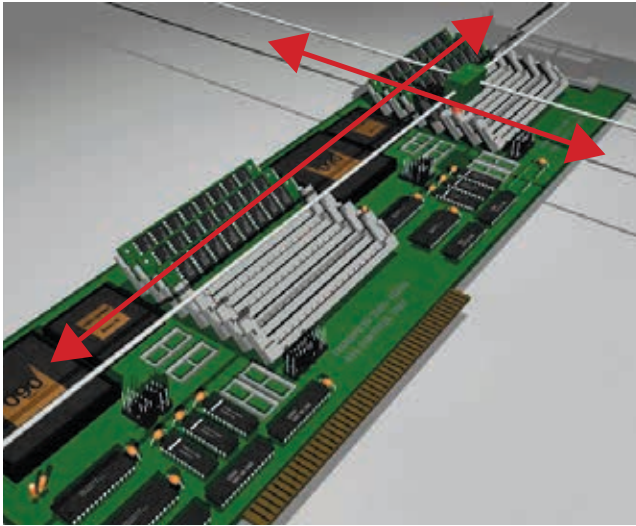

Solution 1 To improve productivity

Fine tuning and feed forward gain

Solution 2 To reduce the vibrations of the machine.

Auto damping control and anti-resonant frequency for damping

## 02 Takeout robot

Used to take out formed products and convey workpieces

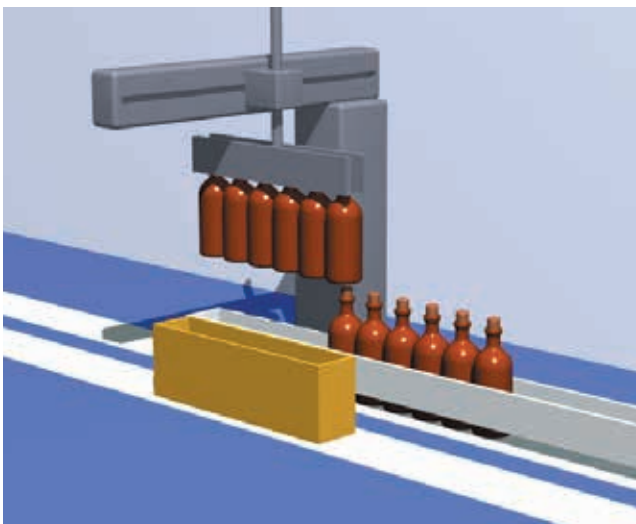

Solution 1 To reduce the vibrations of the machine

Auto damping control and anti-resonant frequency for damping

Solution 2 To suppress the resonance of the machine

Tuningless and notch filter features

Solution 3 To prevent objects from being caught in the machine

Interference detection feature

## 03 Vertical wrapping machine

Used to fill or wrap food or chemical



**Solution 1** To eliminate defective workpieces by synchronizing the feed, seal, and cut axes

Interpolation operation mode and feed forward control

**Solution 2** To cut the material at the position of the reference mark

Enable interrupt input

## 04 Label wrapping machine

Used to wrap labels around bottles

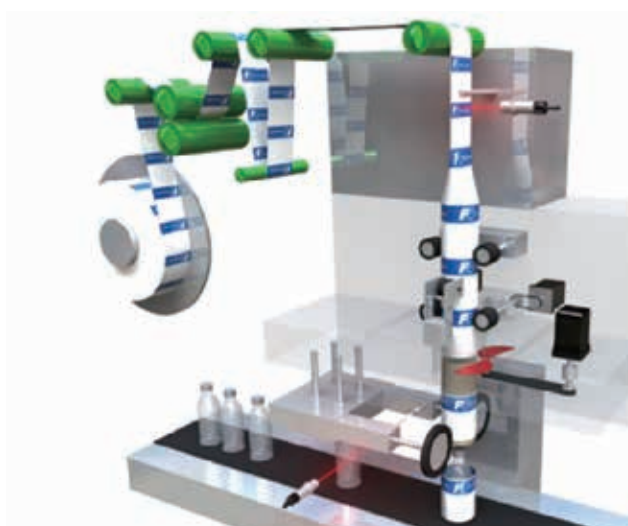

**Solution 1** To improve productivity

Fine tuning and feed forward gain

**Solution 2** To cut the material at the position of the reference mark

Enable interrupt input

# Model Codes (ALPHA7S)

## Servo Amplifier

R Y T 2 0 1 S 7 - V V S 2

Digit	Specifications	Code
1	Basic type	
	ALPHA Series	RYT
2	Capacity	
	10×10 <sup>1</sup> = 100 W	101
	20×10 <sup>1</sup> = 200 W	201
	40×10 <sup>1</sup> = 400 W	401
	75×10 <sup>1</sup> = 750 W	751
	85×10 <sup>1</sup> = 850 W	851
	13×10 <sup>2</sup> = 1300 W	132
	18×10 <sup>2</sup> = 1800 W	182
	29×10 <sup>2</sup> = 2900 W	292
	44×10 <sup>2</sup> = 4400 W	442
3	Series	
	ALPHA7S Series	S
4	Development order	
	7	7
5	Major functions	
	EtherCAT	VCS
	General-purpose interface (Pulse, analog, positioning)	VVS
6	Input voltage	
	3-phase 200 V	2

## Servomotor

G Y S 5 0 0 D 7 - E B 2 - B

Digit	Specifications	Code	
1	Basic type		
	Ultra-low inertia	GYS	
	Medium inertia	GYB	
	Medium inertia	GYE	
2	Medium inertia	GYL	
	Rated output		
	50×10 <sup>0</sup> = 50 W	500	
	10×10 <sup>1</sup> = 100 W	101	
	20×10 <sup>1</sup> = 200 W	201	
	40×10 <sup>1</sup> = 400 W	401	
	75×10 <sup>1</sup> = 750 W	751	
	85×10 <sup>1</sup> = 850 W	851	
	10×10 <sup>2</sup> = 1000 W	102	
	13×10 <sup>2</sup> = 1300 W	132	
	15×10 <sup>2</sup> = 1500 W	152	
	18×10 <sup>2</sup> = 1800 W	182	
	20×10 <sup>2</sup> = 2000 W	202	
	29×10 <sup>2</sup> = 2900 W	292	
	44×10 <sup>2</sup> = 4400 W	442	
	3	Rated speed	
		3000 r/min	D
	4	1500 r/min	B
Development order			
5	6	6	
	7	7	
5	Encoder		
	24-bit ABS	E	
	24-bit INC	N	
	17-bit ABS	P	
	17-bit INC	T	
6	17-bit INC (magnetic)	G	
	Oil seal/shaft <sup>1,2</sup>		
	Without oil seal, straight shaft, with key	A	
	Without oil seal, straight shaft, without key	B	
	Without oil seal, straight shaft, with key, tapped	C	
	With oil seal, straight shaft, with key	E	
	With oil seal, straight shaft, without key	F	
With oil seal, straight shaft, with key, tapped	G		
7	Input voltage		
	3-phase 200 V	2	
8	Brake <sup>3</sup>		
	Without brake	No marking	
	With brake	B	
	Without brake (GYB connector type)	C	
	With brake (GYB connector type)	D	

\*1) GYS motors with keys are not tapped for voltages of 0.1 kW or less and are tapped for voltages of 0.2 kW or more.

\*2) Types with oil seals are made-to-order, so some specifications may differ from those of standard stock products.

\*3) Select unmarked or B type for GYB lead wire types.

# Specifications: Servo Amplifier (ALPHA7S)

Amplifier type		RYT□□□S7-V△S2	101	201	401	751	851	132	182	292	442
Outer frame number			Frame 1			Frame 2a	Frame 2b		Frame 3		Frame 4
Mass [kg]			0.8	0.8	0.8	1.8	1.5	1.5	2.5	2.5	3.8
Protective construction/cooling			Open/natural cooling				Open/mechanical cooling				
Power supply	Main power supply	Number of phases	Single-phase, 3-phase				3-phase				
		Voltage/frequency	200 to 240 VAC, 50/60 Hz								
		Allowable voltage fluctuation	3-phase: 170 to 264 VAC, Single-phase: 190 to 264 VAC								
	Control Power supply	Number of phases	None								
Voltage/frequency											
Allowable voltage fluctuation											
Control system			Fully-digital sinusoidal PWM drive								
Overload capacity			Overload capability varies from motor to motor								
Regenerative resistor Max voltage [W]	Built-in resistor		-	-	-	20	20	20	30	30	60
	External resistor <sup>1</sup>		17	17	17	50	50	50	260	260	300
Dynamic brake			Built-in								
Feedback			Absolute 24-bit/17-bit serial encoder, incremental 24-bit/17-bit serial encoder								
Speed fluctuation ratio <sup>2</sup>	Load fluctuation		Within ± 0.01% (load fluctuation 0 to 100% at rated operation speed)								
	Power supply fluctuation		0% (power supply fluctuation -10% to +10% at rated operation speed)								
	Temperature fluctuation		Within ± 0.2% (25°C ± 10%°C at rated operation speed when an analog voltage command is issued)								
Performance	VVS type	Speed control	Closed-loop control, acceleration time setting, manual feed speed/maximum rotation speed adjustment, speed command zero clamping, etc. by using a speed regulator								
		Number of position data points	50 points (position, speed, acceleration time, deceleration time, stop timer, M code output, and various statuses)								
		Position control	Closed-loop control, electronic gear, output pulse setting, feed forward, homing, interrupt positioning, auto start, etc. by using a position regulator								
		Torque control	Closed-loop control (proportional open-loop control for current and torque), torque limiting, speed limiting during torque control, etc. by using a current regulator								
	VCS type	Ancillary features	Easy tuning, pattern run, sequence test mode, auto tuning, auto notch filter, vibration suppression control online learning, etc.								
		Speed control	Closed-loop control, acceleration/deceleration time setting, manual feed speed/maximum rotation speed adjustment, etc. by using a speed regulator								
		Position control	Closed-loop control, electronic gear, output pulse setting, feed forward, homing, interrupt positioning, etc. by using a position regulator								
		Torque control	Closed-loop control (proportional open-loop control for current and torque), torque limiting, speed limiting during torque control, etc. by using a current regulator								
Protective functions (Alarm display)	VVS type	Over Current (oc1, oc2), Over Speed (oS), Overvoltage (Hv), Encoder Trouble (Et1, Et2), Control Circuit Error (ct), Memory Error (dE), Motor Combination Error (cE), Encoder Communication Error (Ec), CONT (Control signal) Error (ctE), Over Load (oL1, oL2, oL3), Main Power Low Voltage (LvP), Braking Resistor Overheat (rH1, rH2), Braking Transistor Error (rH3), Inrush Current Suppression Circuit Trouble (rH4), Deviation Overflow (oF), Amplifier Overheat (AH), Encoder Overheat (EH), Absolute Data Lost (dL1, dL2, dL3), Multi-turn Data Over Flow (AF), Initial Error (iE), Command Pulse Frequency Error (HF)									
	VCS type	Over Current (oc01, oc02), Over Speed (oS), Overvoltage (Hv), Encoder Trouble (Et01, Et02), Control Circuit Error (ct), Memory Error (dE), Motor Combination Error (cE), Encoder Communication Error (Ec), CONT (Control signal) Error (cont), Over Load (oL01, oL02, oL03), Main Power Low Voltage (LvPE), Braking Resistor Overheat (rH01, rH02), Braking Transistor Error (rH03), Inrush Current Suppression Circuit Trouble (rH04), Deviation Overflow (oF), Amplifier Overheat (AH), Encoder Overheat (EH), Absolute Data Lost (dL01, dL02, dL03), Multi-turn Data Over Flow (AF), Initial Error (iE), Command Pulse Frequency Error (HF), EtherCAT Communication Error (cy) * If the message is four-digit, two digits of the message alternately appear at a time on the 7-segment LED.									
Operation and display section of main body	VVS type	5-digit alphanumeric display with 7-segment LED 4 operation switches (MODE, UP, DOWN, and SET)									
	VCS type	2-digit alphanumeric display with 7-segment LED Rotary switch									
Use Environment	Installation place	Indoors at altitude ≤ 1000 m, free from dust, corrosive gases and direct sunlight In case of compliance with UL/CE marking: Pollution Degree = 2 Over Voltage Category = III									
	Temperature/humidity/Atmospheric pressure	0 to 55°C/10 to 90%RH (without condensation)/70 to 106 kPa									
	Vibration resistance	3 mm: < 2 to 9 Hz 9.8 m/s <sup>2</sup> : < 9 to 20 Hz 2 m/s <sup>2</sup> : < 20 to 55 Hz 1 m/s <sup>2</sup> : < 55 to 200 Hz									
	Shock resistance	19.6 m/s <sup>2</sup>									
Standards			UL standard: UL61800-5-1 CE marking Low voltage directive: EN61800-5-1 EMC directive: EN61800-3 KC								
Control function	Frequency response		3,200 Hz								
	Tuning features		Auto tuning, semi-auto tuning, interpolation control mode, trace operation mode, high-tact operation mode, custom tuning mode, manual tuning								
	Automatic adjustment features		Tuningless features, easy tuning, fine tuning								
	Notch filter		5-step								
	Damping control		Uses only one point: Switchable at 4 points; uses 2 points simultaneously: Fixed at PA1_78 and PA1_80 (not switchable)								
Compensation features			Friction compensation, interference detection, cogging torque compensation								

<sup>1</sup> This value assumes that the external resistor dedicated to each amplifier is connected.

<sup>2</sup> This value represents the average value of the speed fluctuation that is generated from static load fluctuation, power supply fluctuation, and temperature fluctuation as the percentage to the rated rotation speed.

# Specifications: VVS Type Servo Amplifier (ALPHA7S)

Outline of System Configuration

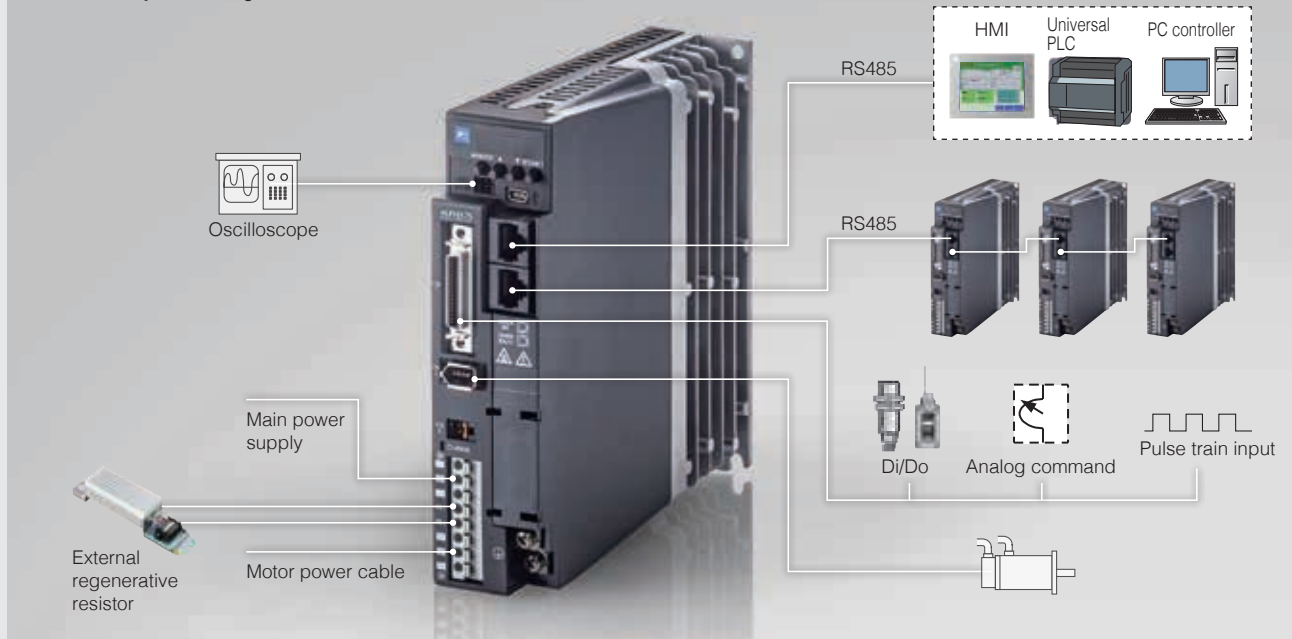

## Interface specifications

Interface type		Specifications		
Command interface	Positioning function	RS-485 (Modbus-RTU), Di/Do		
	Position control	Pulse train input		
	Speed control	Analog voltage input		
	Torque control	Analog voltage input		
Communication interface		Dual RS-485 ports (for parameter editing and monitoring) Our original protocol, Modbus-RTU 9600/19200/38400/115200 bps, connection of max. 31 axes		
Terminal name	Symbol	Specifications		
Pulse train input Also used for CONT signal	CA, *CA CB, *CB	Differential input: Max. input frequency $\leq 4.0$ MHz Open collector input: Max. input frequency $\leq 200$ kHz (In case of signals at $90^\circ$ phase difference, the above relationship is true for the four-fold frequency.) Pulse train format: <table border="0"> <tr> <td rowspan="3">                     {                      Command pulse/Command direction                      Forward/Reverse pulse                      Two signals at <math>90^\circ</math> phase difference                      }                 </td> <td>Select with parameters from here</td> </tr> </table>	{ Command pulse/Command direction Forward/Reverse pulse Two signals at $90^\circ$ phase difference }	Select with parameters from here
	{ Command pulse/Command direction Forward/Reverse pulse Two signals at $90^\circ$ phase difference }	Select with parameters from here		
PPI		CA,*CA: CONT CA signal, CB,*CB: CONT CB signal, compatible with both sink input and source input Pull-up power input at open collector input (24 VDC $\pm$ 10%)		
Pulse train output Also used for OUT signal		FFA, *FFA FFB, *FFB	Differential output: Max. output frequency $\leq 1.0$ MHz Two signals at $90^\circ$ phase difference Pulse output count setting (n pulses/rev): $16 \leq n \leq 4194304$	
	FFZ, *FFZ	Differential output: 1 pulse/rev		
	FA, FB	AB phase output (Open collector output) Maximum voltage: 30 VDC, Maximum current: 50 mA FA·FB: OUT FA·FB signal		
	FZ	Z phase (Open collector output) 1 pulse/rev, FZ: OUT FZ signal		
Analog monitor Voltage output	MON1 MON2	Reference potential (0 V) 0 V to $\pm 10$ VDC Resolution: 14 bits / $\pm$ full scale The output data depends on the internal parameter		
	M5	Reference potential (0 V)		
Common for sequence input/output signal	COMIN	Common for sequence input signal		
	COMOUT	Common for sequence output signal		
Sequence input signal	CONT1 to CONT8	ON upon short circuit across contacts, OFF upon open circuit 12 VDC-10% to 24 VDC+10% Current consumption 12 mA (per contact; used at circuit voltage 24 VDC) Function of each signal depends on parameter setting Compatible with both sink and source input methods		
Sequence output signal	OUT1 to OUT4	Short circuit upon ON, open circuit upon OFF 30 VDC / 50 mA (max.) Function of each signal depends on parameter setting Compatible with both sink and source output methods		
Analog voltage input	VREF	Speed command input when performing speed control Valid input range: -10 V to 0 to +10 V, input impedance: 20 k $\Omega$ Resolution: 16 bits / $\pm$ full scale		
	TREF	Torque command input when performing torque control Valid input range: -10 V to 0 to +10 V, input impedance: 20 k $\Omega$ Resolution: 16 bits / $\pm$ full scale		
	M5	Reference potential (0 V)		

# Specifications: VCS Type Servo Amplifier (ALPHA7S)

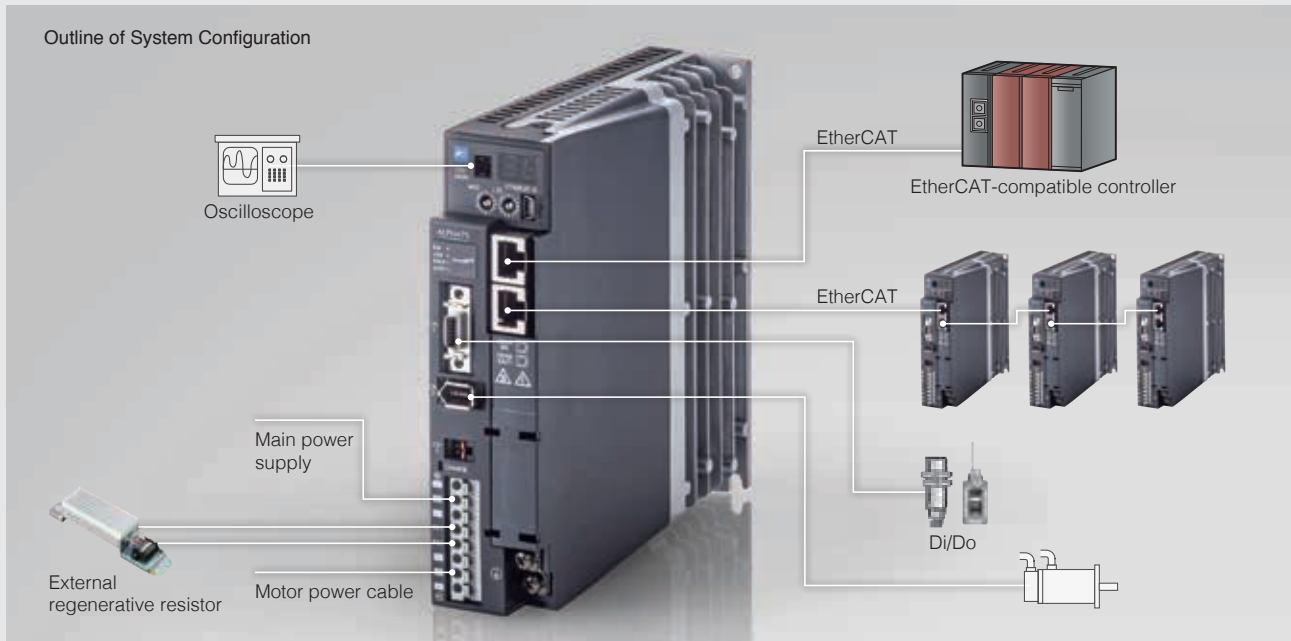

## Interface specifications

Interface type		Specifications
Command interface	Position control	EtherCAT CiA402 drive profile
	Speed control	
	Torque control	
Communication interface		EtherCAT (for command interface, parameter editing, and monitoring) Can application over EtherCAT 100 Mbps

## EtherCAT communication specifications

Item	Specifications
Physical layer	100Base-TX [IEEE802.3]
Baud rate	100 Mbps (Full duplex)
Topology	Line
Communication cable	Twist pair cable CAT5e
Communication distance	Node-to-node distance: Max. 100 m
Number of slaves	65535 * The number of slaves that can be controlled with PDO is limited depending on the communication cycle and data length.
Communication port	2 ports (RJ45 connectors)
Station alias (Station alias)	Setting range: 0 to 65535
Device profile	CAN application over EtherCAT pp: Profile position mode pv: Profile velocity mode hm: Homing mode csp: Cyclic synchronous position mode csv: Cyclic synchronous velocity mode cst: Cyclic synchronous torque mode tg: Torque profile mode ip: Interpolated position mode
Touch probe	Supported (two inputs)
Synchronization method	Synchronous mode DC: Distribute clock SM2: Cyclic PDO communication
	Asynchronous mode Free RUN
Communication cycle	125 [μs], 250 [μs], 500 [μs], 1000 [μs], 2000 [μs], 4000 [μs]
Communication form	SDO, PDO
SDO message	Normal Request, Normal Response
Free PDO Mapping	Supported *Only the objects defined to be supportable in our specifications
Maximum PDO data count	4x16 [Entry/PDO] (RxPDO) + 4x16 [Entry/PDO] (TxPDO)
Maximum PDO data length	128 [bytes] (Rx PDO) + 128 [bytes] (Tx PDO)

Terminal name	Symbol	Specifications
Analog monitor voltage output	MON1 MON2	0 V to ±10 VDC Resolution: 14 bits / ± full scale The output data depends on the internal parameter
	M5	Reference potential (0 V)
Common for sequence input/output signal	COMIN	Common for sequence input signal
	COMOUT	Common for sequence output signal (OUT1 · OUT2)
	COMOUT13	Common for sequence output signal (OUT13)
Sequence input signal	CONT1 to CONT6	ON upon short circuit across contacts, OFF upon open circuit 12 VDC-10% to 24 VDC+10% Current consumption 12 mA (per contact; used at circuit voltage 24 VDC) Function of each signal depends on parameter setting Compatible with both sink and source input methods
Sequence output signal	OUT1 to 2 / OUT13	Short circuit upon ON, open circuit upon OFF 30 VDC / 50 mA (max.) Function of each signal depends on parameter setting OUT1 · OUT2 : Compatible with both sink and source output methods OUT13 : Compatible with sink output methods

# Connection Diagram for Reference: ALPHA7S VVS Type Servo Amplifier (Frame 1)

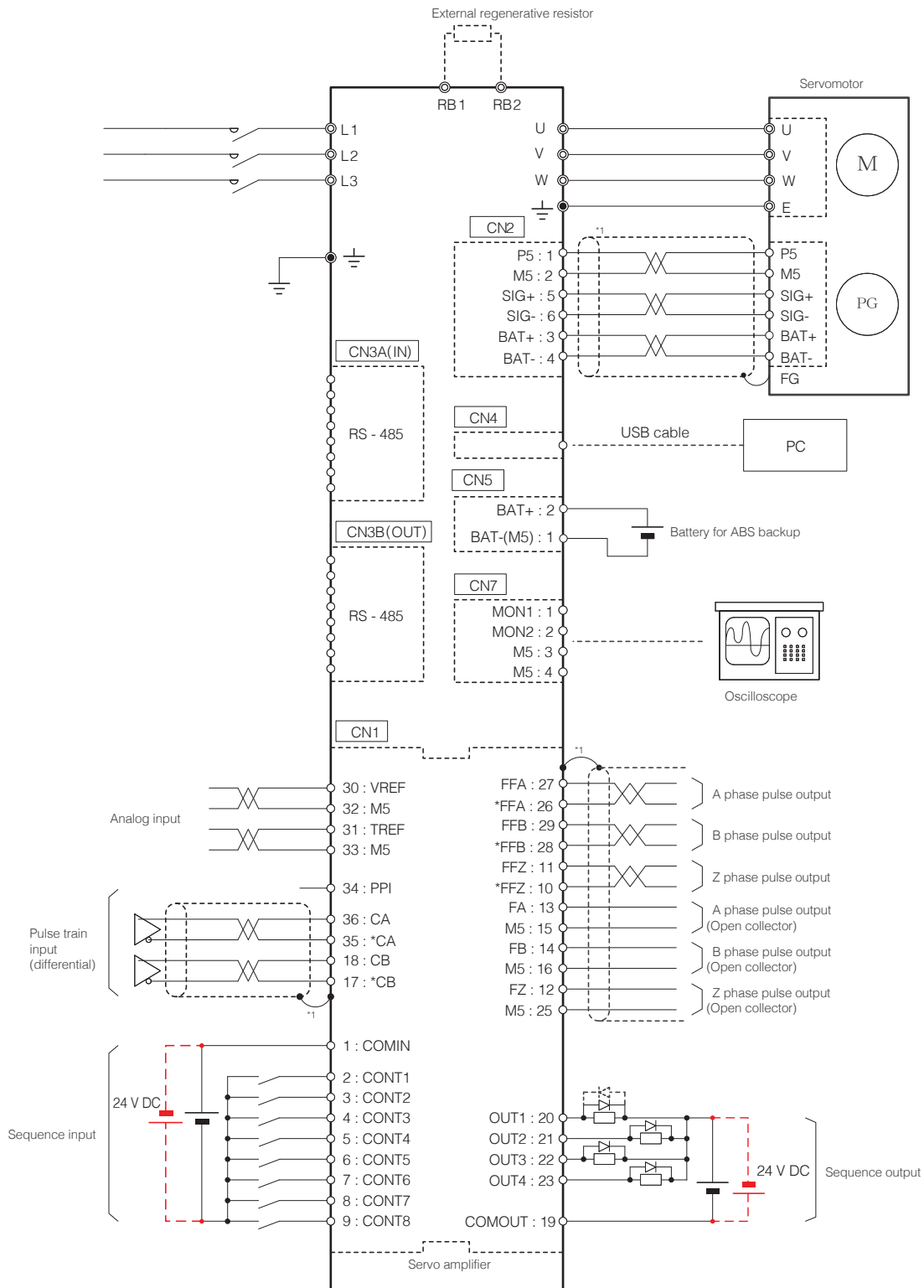

\*1 The shielded wire on the servo amplifier side connects to the connector shell.



The diagram shown above is intended as a reference for model selection. When actually using the selected servo system, always make wiring connections according to the connection diagram and instructions described in the user's manual.

# Connection Diagram for Reference: ALPHA7S VCS Type Servo Amplifier (Frame 1)

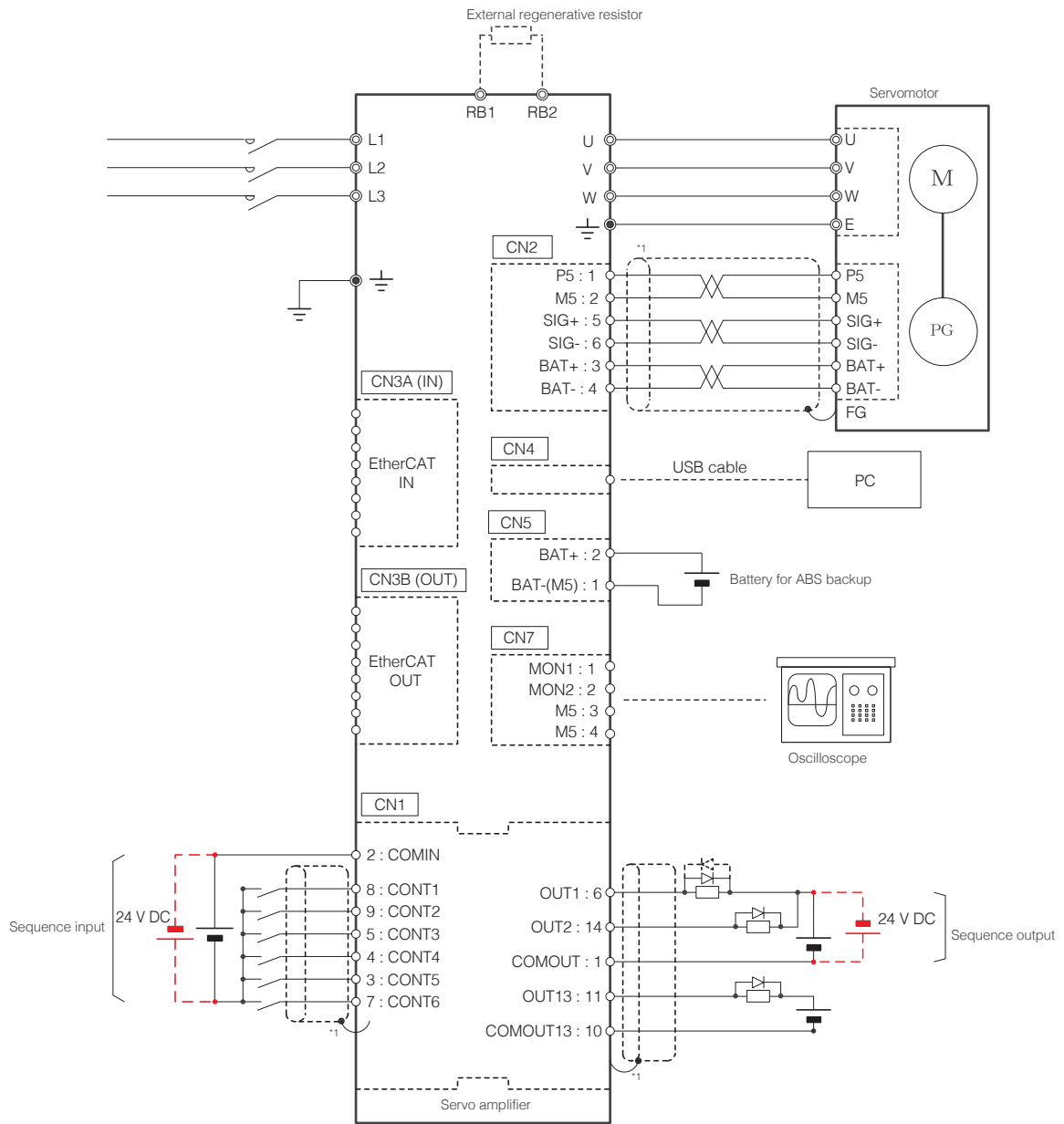

\*1 The shielded wire on the servo amplifier side connects to the connector shell.



The diagram shown above is intended as a reference for model selection. When actually using the selected servo system, always make wiring connections according to the connection diagram and instructions described in the user's manual.

# Servomotor Specifications: GYS motor

## Standard specifications

Motor type	GYS500D7-□□2	GYS101D7-□□2	GYS201D7-□□2	GYS401D7-□□2	GYS751D7-□□2
Rated output [kW]	0.05	0.1	0.2	0.4	0.75
Rated torque [N·m]	0.159	0.318	0.637	1.27	2.39
Rated speed [r/min]	3000				
Max. speed [r/min]	6000				
Max. torque [N·m]	0.478	0.955	1.91	3.82	7.17
Inertia [kg·m <sup>2</sup> ]	0.0192×10 <sup>-4</sup>	0.0371×10 <sup>-4</sup>	0.135×10 <sup>-4</sup>	0.246×10 <sup>-4</sup>	0.853×10 <sup>-4</sup>
Rated current [A]	0.85	0.85	1.5	2.7	4.8
Max. current [A]	2.55	2.55	4.5	8.1	14.4
Insulation class	Class B				
Winding insulation class	Totally enclosed, self-cooled, IP67 (excluding the shaft sealing and connectors)*1				
Terminals (motor)	Cable 0.3 m (with connector)				
Terminal (encoder)	Cable 0.3 m (with connector)				
Overheat protection	Not provided (The servo amplifier detects temperature)				
Mounting method	Flange mounting IMB5 (L51), IMV1 (L52), IMV3 (L53)				
Encoder	24-bit serial encoder (absolute/incremental)				
Vibration*2	V5 or below				
Installation place, environment	For indoor use (free from direct sunlight), locations without corrosive and flammable gases, oil mist and dust				
Altitude	Altitude ≤ 1000 m				
Ambient temperature, humidity	-10 to +40°C (without freezing), within 90% RH max. (without condensation)				
Vibration resistance [m/s <sup>2</sup> ]	49				
Mass [kg]	0.45	0.55	1.2	1.8	3.4
Standards	UL/cUL (UL1004), CE marking (EN60034-1, EN60034-5), RoHS directive				

\*1 When using the product under such an environment as specified in IP67, make sure that the connector for wiring is compatible with IP67.

\*2 The vibration value is the property of flange type IMV1 (L52).

## Brake specifications (motor equipped with a brake)

Motor type	GYS500D7-□□2-B	GYS101D7-□□2-B	GYS201D7-□□2-B	GYS401D7-□□2-B	GYS751D7-□□2-B
Rated output [kW]	0.05	0.1	0.2	0.4	0.75
Rated torque [N·m]	0.159	0.318	0.637	1.27	2.39
Inertia [kg·m <sup>2</sup> ]	0.0223×10 <sup>-4</sup>	0.0402×10 <sup>-4</sup>	0.159×10 <sup>-4</sup>	0.270×10 <sup>-4</sup>	0.949×10 <sup>-4</sup>
Static friction torque [N·m]	0.34		1.27		2.45
Rated voltage [V]	24 VDC ±10%				
Attraction time [ms]	35		40		60
Release time [ms]	10		20		25
Power consumption [W]	6.1 (at 20°C)		7.3 (at 20°C)		8.5 (at 20°C)
Mass [kg]	0.62	0.72	1.7	2.3	4.2

## Torque characteristics diagrams (amplifier power supply voltage: at 3-phase 200 V or single-phase 230 V)

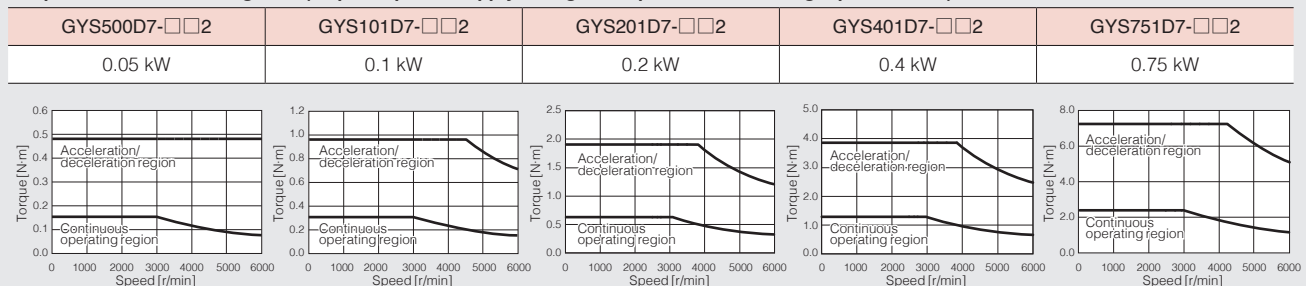

These characteristics indicate typical values of each servomotor combined with the corresponding RYT-7 type servo amplifier.

The rated torque indicates the value obtained when the servo amplifier is installed to the following aluminum heat sink.

- Model GYS500D, 101D: 200 × 200 × 6 [mm]
- Model GYS201D, 401D: 250 × 250 × 6 [mm]
- Model GYS751: 300 × 300 × 6 [mm]

# Servomotor Specifications: GYS motor

## Standard specifications

Motor type	GYS102D7-□□2	GYS152D7-□□2	GYS202D7-□□2
Rated output [kW]	1.0	1.5	2.0
Rated torque [N·m]	3.18	4.78	6.37
Rated speed [r/min]	3000		
Max. speed [r/min]	5000		
Max. torque [N·m]	9.55	14.3	19.1
Inertia [kg · m <sup>2</sup> ]	1.73×10 <sup>-4</sup>	2.37×10 <sup>-4</sup>	3.01×10 <sup>-4</sup>
Rated current [A]	7.1	9.6	12.6
Max. current [A]	21.3	28.8	37.8
Insulation class	Class F		
Winding insulation class	Totally enclosed, self-cooled, IP67 (excluding the shaft sealing)*1		
Terminals (motor)	Cannon connector		
Terminal (encoder)	Cannon connector		
Overheating protection	Not provided (The servo amplifier detects temperature)		
Mounting method	Flange mounting IMB5 (L51), IMV1 (L52), IMV3 (L53)		
Encoder	24-bit serial encoder (absolute/incremental)		
Vibration level*2	Up to rated rotation speed: V10 or below Over rated rotation speed and up to 5000 r/min: V15 or below		
Installation place, environment	For indoor use (free from direct sunlight), locations without corrosive and flammable gases, oil mist and dust		
Altitude	Altitude ≤ 1000 m		
Ambient temperature, humidity	-10 to +40°C (without freezing), within 90% RH max. (without condensation)		
Vibration resistance [m/s <sup>2</sup> ]	24.5		
Mass [kg]	4.4	5.2	6.3
Standards	UL/cUL (UL1004), CE marking (EN60034-1, EN60034-5), RoHS directive		

\*1 When using the product under such an environment as specified in IP67, make sure that the connector for wiring is compatible with IP67

\*2 The vibration value is the property of flange type IMV1 (L52).

## Brake specifications (motor equipped with a brake)

Motor type	GYS102D7-□□2-B	GYS152D7-□□2-B	GYS202D7-□□2-B
Rated output [kW]	1.0	1.5	2.0
Rated torque [N·m]	3.18	4.78	6.37
Inertia [kg · m <sup>2</sup> ]	2.03×10 <sup>-4</sup>	2.67×10 <sup>-4</sup>	3.31×10 <sup>-4</sup>
Static friction torque [N·m]	6.86		
Rated DC voltage [V]	24 VDC ±10%		
Attraction time [ms]	100		
Release time [ms]	40		
Power consumption [W]	17.7 (at 20°C)		
Mass [kg]	5.9	6.8	7.9

## Torque characteristics diagrams (amplifier power supply voltage: at 3-phase 200 V)

GYS102D7-□□2	GYS152D7-□□2	GYS202D7-□□2
1.0 kW	1.5 kW	2.0 kW

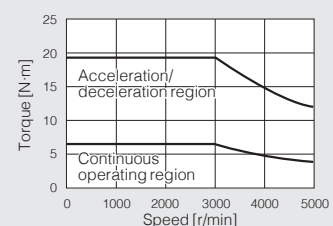
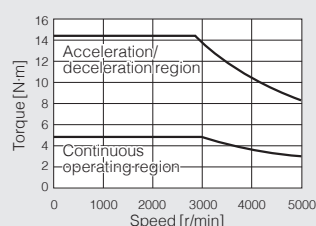
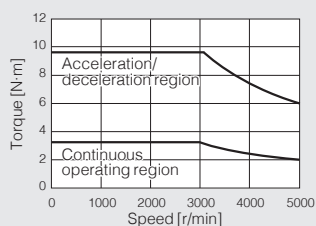

These characteristics indicate typical values of each servomotor combined with the corresponding RYT-7 type servo amplifier.

The rated torque indicates the value obtained when the servo amplifier is installed to the following aluminum heat sink.

- Model GYS102D, 152D, 202D: 350 × 350 × 8 [mm]

# Servomotor Specifications: GYB motor

## Standard specifications

Motor type	GYB500D7-□□2-□	GYB101D7-□□2-□	GYB201D7-□□2-□	GYB401D7-□□2-□	GYB751D7-□□2-□
Rated output [kW]	0.05	0.1	0.2	0.4	0.75
Rated torque [N·m]	0.159	0.318	0.637	1.27	2.39
Rated speed [r/min]	3000				
Max. speed [r/min]	6000				
Max. torque [N·m]	0.478	0.955	1.91	3.82	7.17
Inertia [kg·m <sup>2</sup> ]	0.0326×10 <sup>-4</sup>	0.0616×10 <sup>-4</sup>	0.33×10 <sup>-4</sup>	0.57×10 <sup>-4</sup>	1.53×10 <sup>-4</sup>
Rated current [A]	1.35	1.35	1.4	2.7	4.9
Max. current [A]	5.2	5.2	6.0	12.0	18.0
Insulation class	Class B				
Winding insulation class	Totally enclosed, self-cooled, IP67 (excluding the shaft sealing and lead wire connectors)*				
Terminals (motor)	Connector (lead wire)				
Terminal (encoder)	Connector (lead wire)				
Overheating protection	Not provided (The servo amplifier detects temperature)				
Mounting method	Flange mounting IMB5 (L51), IMV1 (L52), IMV3 (L53)				
Encoder	24-bit serial encoder (absolute/incremental)				
Vibration level	V5 or below				
Installation place, environment	For indoor use (free from direct sunlight), locations without corrosive and flammable gases, oil mist and dust				
Altitude	Altitude ≤ 1000 m				
Ambient temperature, humidity	-10 to +40°C (without freezing), within 90% RH max. (without condensation)				
Vibration resistance [m/s <sup>2</sup> ]	49				
Mass [kg]	0.3	0.4	0.9	1.2	2.3
Standards	UL/cUL (UL1004), CE marking (EN60034-1, EN60034-5), RoHS directive				

\* When using the product under such an environment as specified in IP67, make sure that the connector for wiring is compatible with IP67.

## Brake specifications (motor equipped with a brake)

Motor type	GYB500D7-□□2-□	GYB101D7-□□2-□	GYB201D7-□□2-□	GYB401D7-□□2-□	GYB751D7-□□2-□
Rated output [kW]	0.05	0.1	0.2	0.4	0.75
Rated torque [N·m]	0.159	0.318	0.637	1.27	2.39
Inertia [kg·m <sup>2</sup> ]	0.0357×10 <sup>-4</sup>	0.0647×10 <sup>-4</sup>	0.37×10 <sup>-4</sup>	0.62×10 <sup>-4</sup>	1.71×10 <sup>-4</sup>
Static friction torque [N·m]	0.34		1.5		3.0
Rated voltage [V]	24 VDC ±10%				
Attraction time [ms]	35		40		60
Release time [ms]	10		20		20
Power consumption [W]	6.1 (at 20°C)		7.2 (at 20°C)		8.5 (at 20°C)
Mass [kg]	0.55	0.65	1.3	1.8	3.2

## Torque characteristics diagrams (amplifier power supply voltage: at 3-phase 200 V or single-phase 230 V)

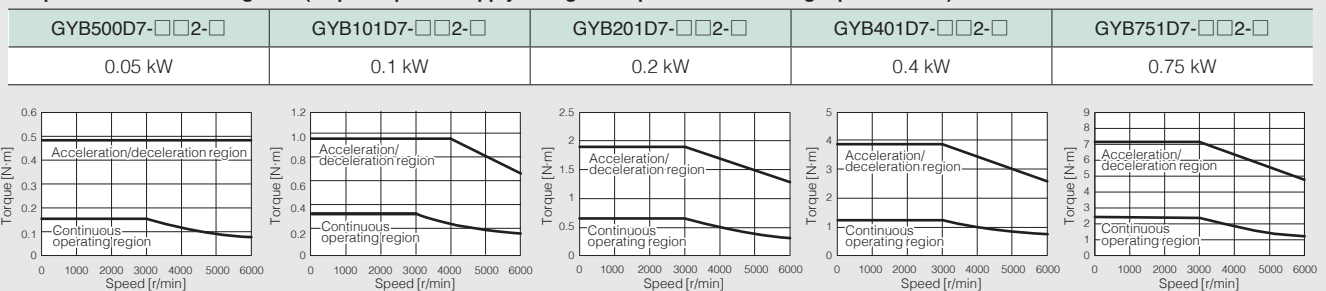

These characteristics indicate typical values of each servomotor combined with the corresponding RYT-7 type servo amplifier.

The rated torque indicates the value obtained when the servo amplifier is installed to the following aluminum heat sink.

- Model GYB500, 101: 200 × 200 × 6 [mm]
- Model GYB201D, 401D: 250 × 250 × 6 [mm]
- Model GYB751D: 300 × 300 × 6 [mm]

# Servomotor Specifications: GYE motor

## Standard specifications

Motor type	GYE201D6-GC2	GYE401D6-GC2	GYE751D6-GC2
Rated output [kW]	0.2	0.4	0.75
Rated torque [N·m]	0.637	1.27	2.39
Rated speed [r/min]	3000		
Max. speed [r/min]	6000		
Max. torque [N·m]	1.91	3.82	7.17
Inertia [kg · m <sup>2</sup> ]	0.26×10 <sup>-4</sup>	0.50×10 <sup>-4</sup>	1.53×10 <sup>-4</sup>
Rated current [A]	1.5	2.5	4.7
Max. current [A]	5.2	8.5	15.6
Insulation class	Class F		
Winding insulation class	Totally enclosed, self-cooled, IP67 (excluding the shaft sealing and lead wire connectors)*		
Terminals (motor)	Cable 0.3 m (with connector)		
Terminal (encoder)	Cable 0.3 m (with connector)		
Overheating protection	Not provided (The servo amplifier detects temperature)		
Mounting method	Flange mounting IMB5 (L51), IMV1 (L52), IMV3 (L53)		
Encoder	17-bit serial encoder (incremental)		
Vibration level	V10 or below		
Installation place, environment	For indoor use (free from direct sunlight), locations without corrosive and flammable gases, oil mist and dust		
Altitude	Altitude ≤ 1000 m		
Ambient temperature, humidity	0 to +40°C, within 90% RH max. (without condensation)		
Vibration resistance [m/s <sup>2</sup> ]	49		
Mass [kg]	0.9	1.2	2.2
Standards	CE marking (EN60034-1, EN60034-5), RoHS directive		

\* When using the product under such an environment as specified in IP67, make sure that the connector for wiring is compatible with IP67.

## Torque characteristics diagrams (amplifier power supply voltage: at 3-phase 200 V or single-phase 230 V)

GYE201D6-GC2	GYE401D6-GC2	GYE751D6-GC2
0.2 kW	0.4 kW	0.75 kW

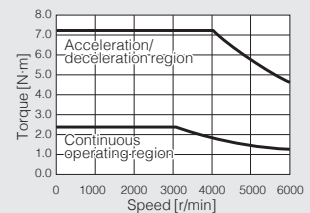
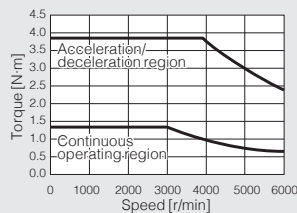
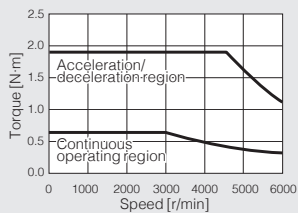

These characteristics indicate typical values of each servomotor combined with the corresponding RYT-7 type servo amplifier.

The rated torque indicates the value obtained when the servo amplifier is installed to the following aluminum heat sink.

- Model GYE201, 401: 250 × 250 × 6 [mm]
- Model GYE751: 400 × 400 × 12 [mm]

# Servomotor Specifications: GYL motor

## Standard specifications

Motor type	GYL851B6-□□2	GYL132B6-□□2	GYL182B6-□□2	GYL292B6-□□2		GYL442B6-□□2
Combination servo amplifier	RYT851S7-□□□2	RYT132S7-□□□2	RYT182S7-□□□2	RYT292S7-□□□2	RYT442S7-□□□2	
Rated output [kW]	0.85	1.3	1.8	2.4	2.9	4.4
Rated torque [N·m]	5.39	8.34	11.5	15.3	18.5	28.4
Rated speed [r/min]	1500					
Max. speed [r/min]	3000					
Max. torque [N·m]	13.85	21.52	28.65	36.67	44.12	70.03
Inertia [kg·m <sup>2</sup> ]	13.34×10 <sup>-4</sup>	20.07×10 <sup>-4</sup>	26.66×10 <sup>-4</sup>	45.55×10 <sup>-4</sup>		65.41×10 <sup>-4</sup>
Rated current [A]	7	11.4	14.8	19.9	24	33.5
Max. current [A]	18.1	32.4	37.4	48	58	85
Insulation class	Class F					
Winding insulation class	Totally enclosed, self-cooled, IP67 (excluding the shaft sealing and lead wire connectors)*					
Terminals (motor)	Canon connector					
Terminal (encoder)	Canon connector					
Overheating protection	Not provided (The servo amplifier detects temperature)					
Mounting method	Flange mounting IMB5 (L51), IMV1 (L52), IMV3 (L53)					
Encoder	17-bit serial encoder (absolute/incremental)					
Vibration level	V15 or below					
Installation place, environment	For indoor use (free from direct sunlight), locations without corrosive and flammable gases, oil mist and dust					
Altitude	Altitude ≤ 1000 m					
Ambient temperature, humidity	0 to +40°C, within 90% RH max. (without condensation)					
Vibration resistance [m/s <sup>2</sup> ]	19.6					
Mass [kg]	6.7	8.9	11.1	18	23.5	
Standards	CE marking (EN60034-1, EN60034-5), RoHS directive					

\* When using the product under such an environment as specified in IP67, make sure that the connector for wiring is compatible with IP67.

## Brake specifications (motor equipped with a brake)

Motor type	GYL851B6-□□2-B	GYL132B6-□□2-B	GYL182B6-□□2-B	GYL292B6-□□2-B		GYL442B6-□□2-B
Rated output [kW]	0.85	1.3	1.8	2.4	2.9	4.4
Rated torque [N·m]	5.39	8.34	11.5	15.3	18.5	28.4
Inertia [kg·m <sup>2</sup> ]	14.04×10 <sup>-4</sup>	20.77×10 <sup>-4</sup>	27.36×10 <sup>-4</sup>	47.96×10 <sup>-4</sup>		67.83×10 <sup>-4</sup>
Static friction torque [N·m]	17			37		
Rated voltage [V]	24 VDC ±10%			24 VDC ±5%		
Attraction time [ms]	140			200		
Release time [ms]	60			80		
Power consumption [W]	19.5			27.5		
Mass [kg]	8.3	10.5	12.7	22.5	28	

## Torque characteristics diagrams (amplifier power supply voltage: at 3-phase 200 V or single-phase 230 V)

GYL851B6-□□2	GYL132B6-□□2	GYL182B6-□□2	GYL292B6-□□2	GYL442B6-□□2
0.85 kW	1.3 kW	1.8 kW	2.9 kW	4.4 kW

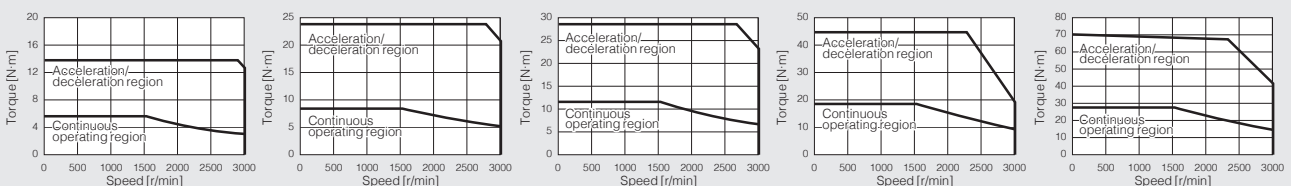

These characteristics indicate typical values of each servomotor combined with the corresponding RYT-7 type servo amplifier.

The rated torque indicates the value obtained when the servo amplifier is installed to the following aluminum heat sink.

- Model GYL851, 132, 182: 400 × 400 × 12 [mm]

- Model GYL292, 442: 600 × 600 × 25 [mm]

# External Dimensions: Servo Amplifier (ALPHA7S)

## VVS type

Frame 1

Unit: mm

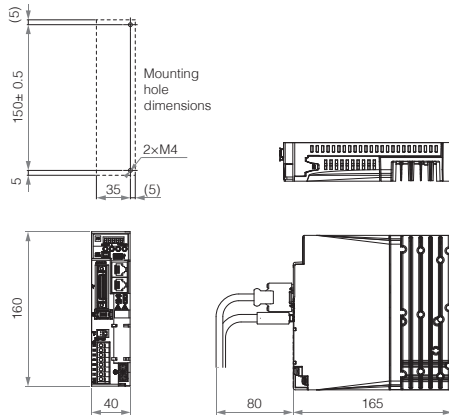

Power supply	Capacity	Type	Mass (kg)
200 V series	0.1 kW	RYT101S7-VVS2	0.8
	0.2 kW	RYT201S7-VVS2	
	0.4 kW	RYT401S7-VVS2	

Frame 2a

Unit: mm

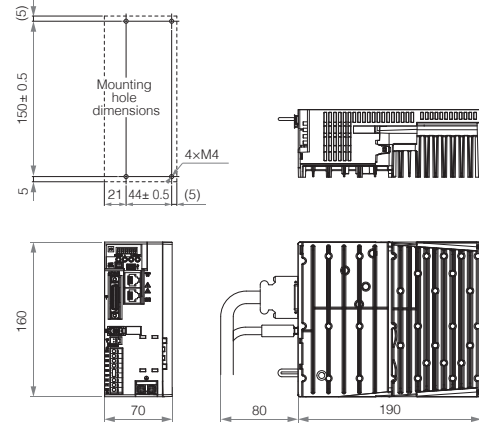

Power supply	Capacity	Type	Mass (kg)
200 V series	0.75 kW	RYT751S7-VVS2	1.8

Frame 2b

Unit: mm

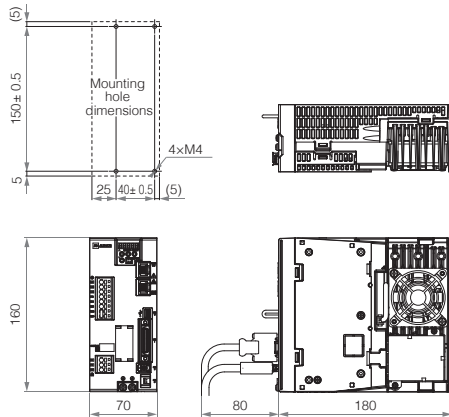

Power supply	Capacity	Type	Mass (kg)
200 V series	0.85 kW	RYT851S7-VVS2	1.5
	1.3 kW	RYT132S7-VVS2	

Frame 3

Unit: mm

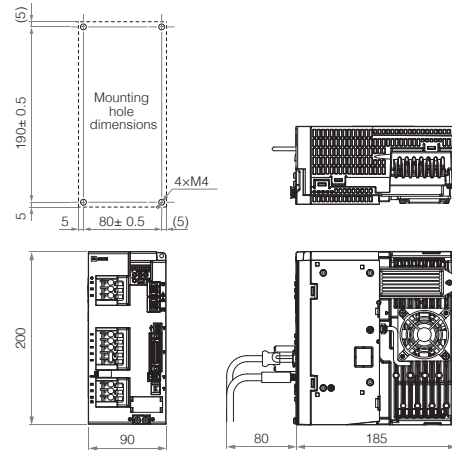

Power supply	Capacity	Type	Mass (kg)
200 V series	1.8 kW	RYT182S7-VVS2	2.5
	2.9 kW	RYT292S7-VVS2	

Frame 4

Unit: mm

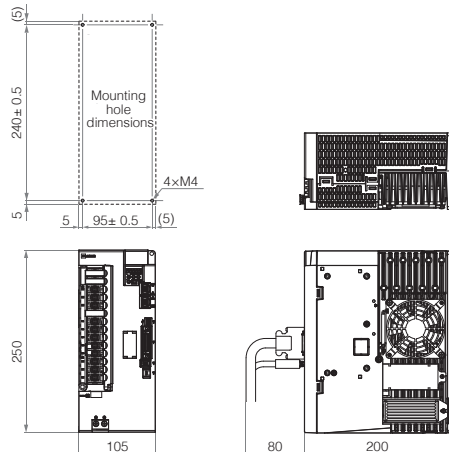

Power supply	Capacity	Type	Mass (kg)
200 V series	4.4 kW	RYT442S7-VVS2	3.8

# External Dimensions: Servo Amplifier (ALPHA7S)

## VCS type

Frame 1

Unit: mm

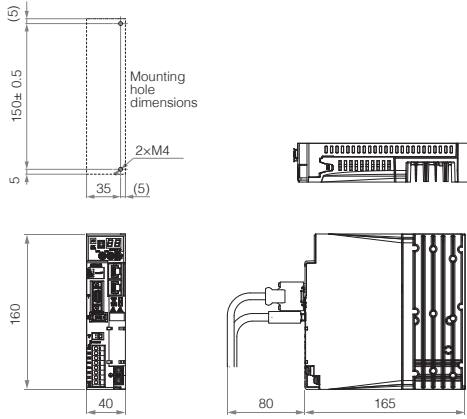

Power supply	Capacity	Type	Mass (kg)
200 V series	0.1 kW	RYT101S7-VCS2	0.8
	0.2 kW	RYT201S7-VCS2	
	0.4 kW	RYT401S7-VCS2	

Frame 2a

Unit: mm

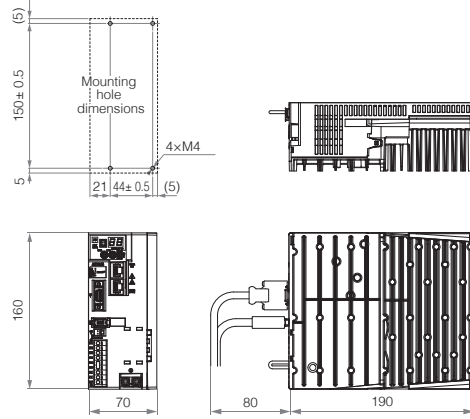

Power supply	Capacity	Type	Mass (kg)
200 V series	0.75 kW	RYT751S7-VCS2	1.8

Frame 2b

Unit: mm

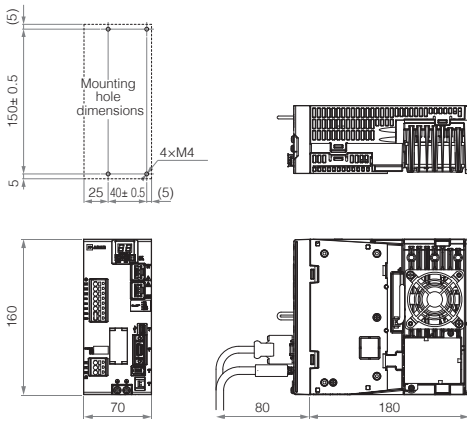

Power supply	Capacity	Type	Mass (kg)
200 V series	0.85 kW	RYT851S7-VCS2	1.5
	1.3 kW	RYT132S7-VCS2	

Frame 3

Unit: mm

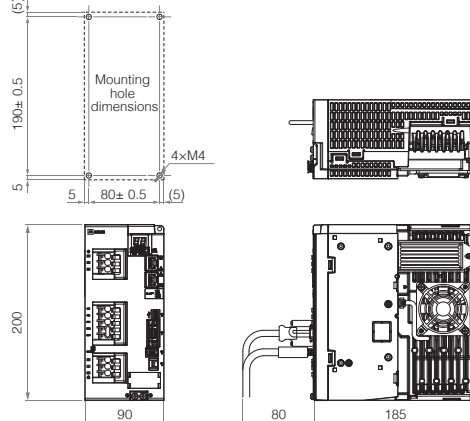

Power supply	Capacity	Type	Mass (kg)
200 V series	1.8 kW	RYT182S7-VCS2	2.5
	2.9 kW	RYT292S7-VCS2	

Frame 4

Unit: mm

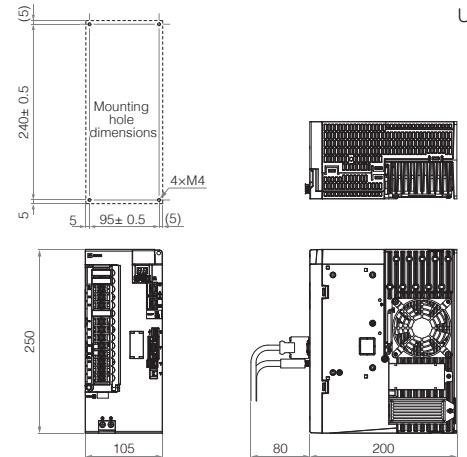

Power supply	Capacity	Type	Mass (kg)
200 V series	4.4 kW	RYT442S7-VCS2	3.8

# External Dimensions: GYS Motor

GYS motor (without brake)

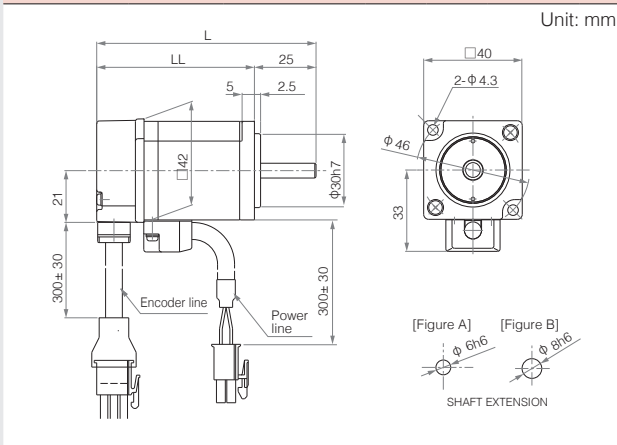

Rated speed	Applicable motor rated output	Type	Shaft shape	Overall length	Dimensions (Flange)	Mass (kg)
				L	LL	
3000 r/min	0.05 kW	GYS500D7-□B2	Figure A	89	64	0.45
	0.1 kW	GYS101D7-□B2	Figure B	107	82	

GYS motor (without brake)

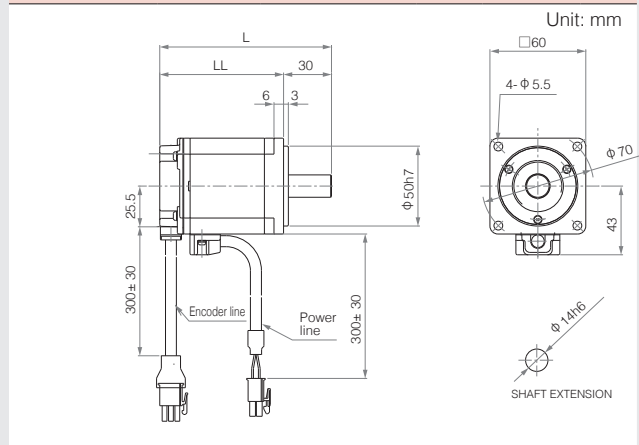

Rated speed	Applicable motor rated output	Type	Overall length	Dimensions (Flange)	Mass (kg)
			L	LL	
3000 r/min	0.2 kW	GYS201D7-□B2	107.5	77.5	1.2
	0.4 kW	GYS401D7-□B2	135.5	105.5	

GYS motor (without brake)

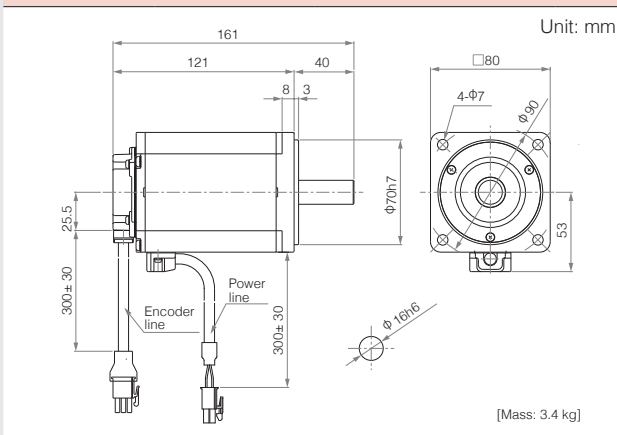

Rated speed	Applicable motor rated output	Type	Mass (kg)
3000 r/min	0.75 kW	GYS751D7-□B2	3.4 kg

GYS motor (without brake)

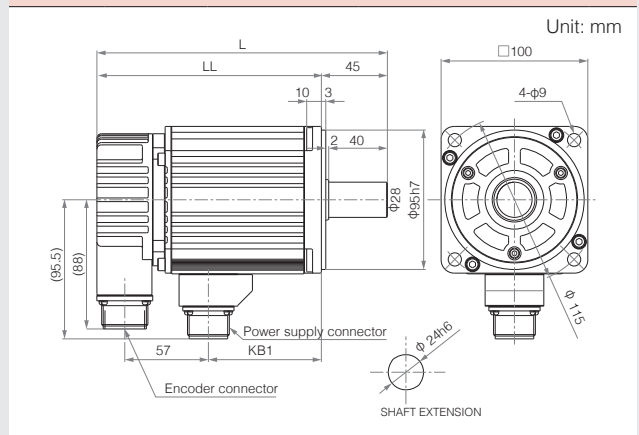

Rated speed	Applicable motor rated output	Type	Overall length	Dimensions (Flange)	Terminal portion	Mass (kg)
			L	LL	KB1	
3000 r/min	1.0 kW	GYS102D7-□B2	198	153	77	4.4
	1.5 kW	GYS152D7-□B2	220.5	175.5	99.5	
	2.0 kW	GYS202D7-□B2	243	198	122	

\*See Page 33 for the shaft extension specifications of the motor with a key.

# External Dimensions: GYS Motor

GYS motor (with brake)

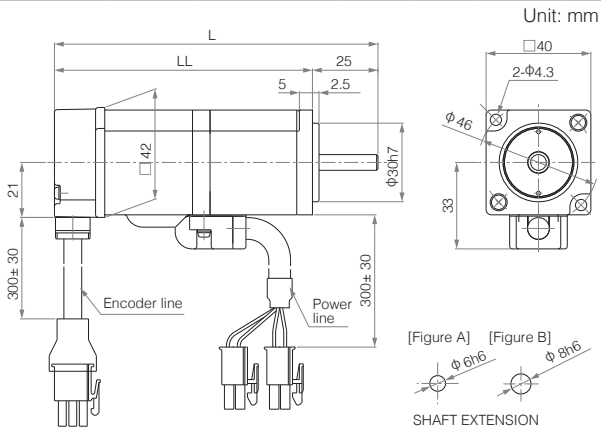

Rated speed	Applicable motor rated output	Type	Shaft shape	Overall length		Mass (kg)
				L	LL	
3000 r/min	0.05 kW	GYS500D7-□B2-B	Figure A	123.5	98.5	0.62
	0.1 kW	GYS101D7-□B2-B	Figure B	141.5	116.5	0.72

GYS motor (with brake)

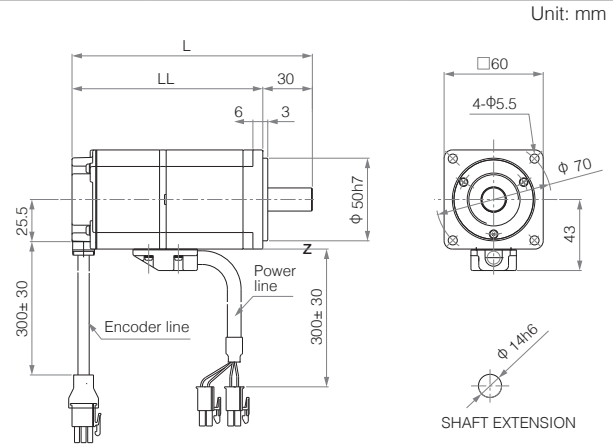

Rated speed	Applicable motor rated output	Type	Overall length		Mass (kg)
			L	LL	
3000 r/min	0.2 kW	GYS201D7-□B2-B	145.5	115.5	1.7
	0.4 kW	GYS401D7-□B2-B	173.5	143.5	2.3

GYS motor (with brake)

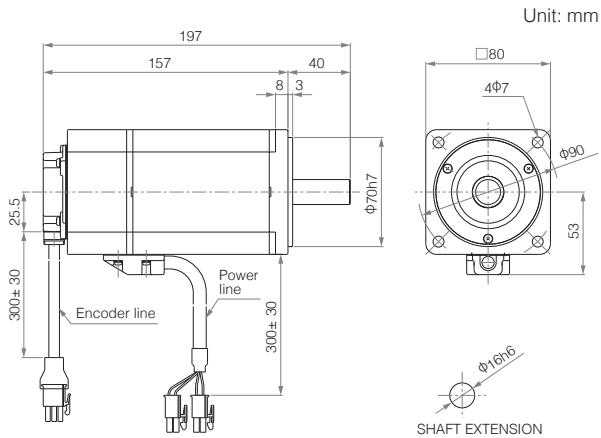

Rated speed	Applicable motor rated output	Type	Mass (kg)
3000 r/min	0.75 kW	GYS751D7-□B2-B	4.2

GYS motor (with brake)

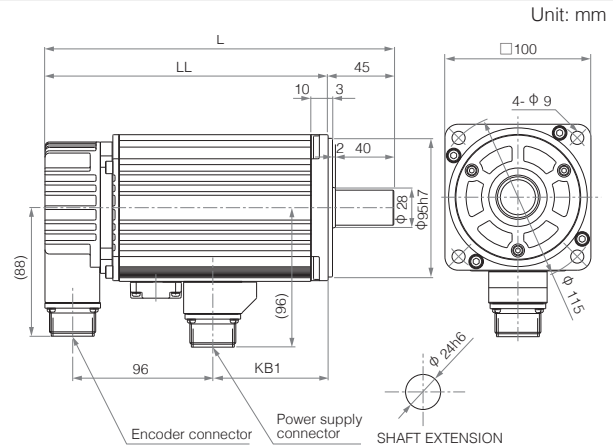

Rated speed	Applicable motor rated output	Type	Overall length		Terminal portion KB1	Mass (kg)
			L	LL		
3000 r/min	1.0 kW	GYS102D7-□B2-B	239	194	79	5.9
	1.5 kW	GYS152D7-□B2-B	261.5	216.5	101.5	6.8
	2.0 kW	GYS202D7-□B2-B	284	239	124	7.9

\*See Page 33 for the shaft extension specifications of the motor with a key.

# External Dimensions: GYB Motor, connector type

GYB motor (without brake)

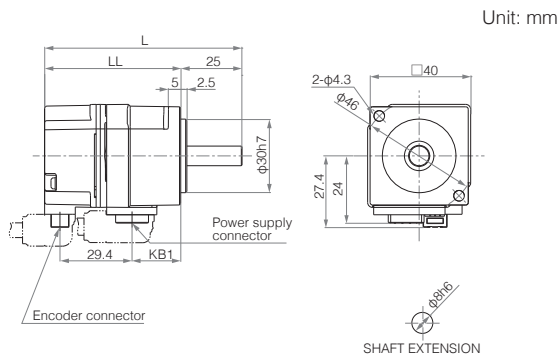

Unit: mm

Rated speed	Applicable motor rated output	Type	Overall length		Terminal portion	Mass (kg)
			L	LL		
3000 r/min	0.05 kW	GYB500D7-□B2-C	80.5	55.5	KB1	0.3
	0.1 kW	GYB101D7-□B2-C	92.5	67.5	KB1	0.4

GYB motor (without brake)

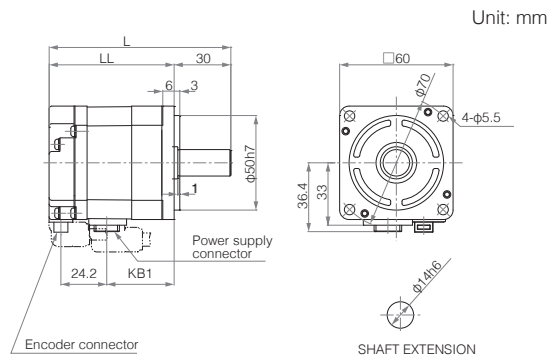

Unit: mm

Rated speed	Applicable motor rated output	Type	Overall length		Terminal portion	Mass (kg)
			L	LL		
3000 r/min	0.2 kW	GYB201D7-□B2-C	96.2	66.2	KB1	0.9
	0.4 kW	GYB401D7-□B2-C	114	84	KB1	1.2

GYB Motor (without brake)

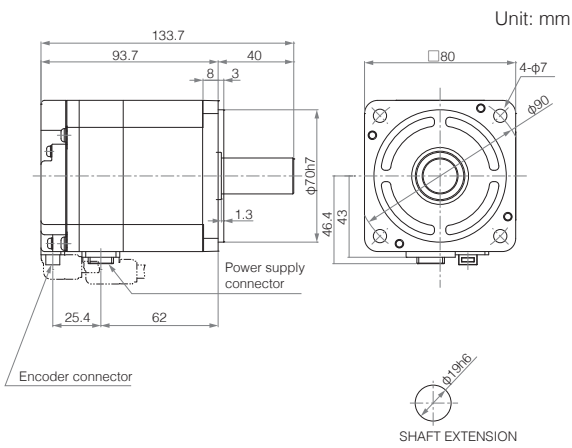

Unit: mm

Rated speed	Applicable motor rated output	Type	Mass (kg)
3000 r/min	0.75 kW	GYB751D7-□B2-C	2.3

GYB motor (with brake)

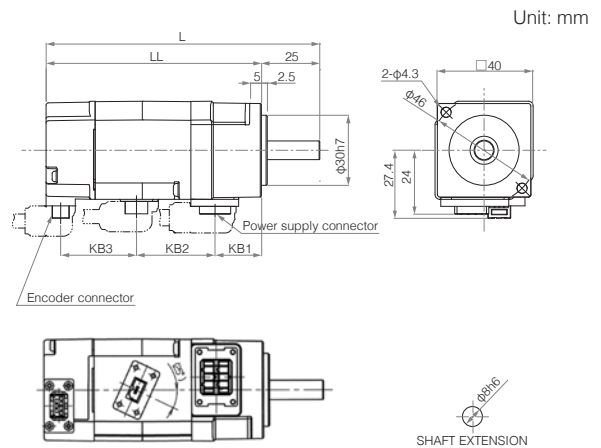

Unit: mm

Rated speed	Applicable motor rated output	Type	Overall length		Terminal portion			Mass (kg)
			L	LL	KB1	KB2	KB3	
3000 r/min	0.05 kW	GYB500D7-□B2-D	117.2	92.2	19.9	33.7	32.5	0.55
	0.1 kW	GYB101D7-□B2-D	129.2	104.2	31.85	33.65	32.45	0.65

GYB motor (with brake)

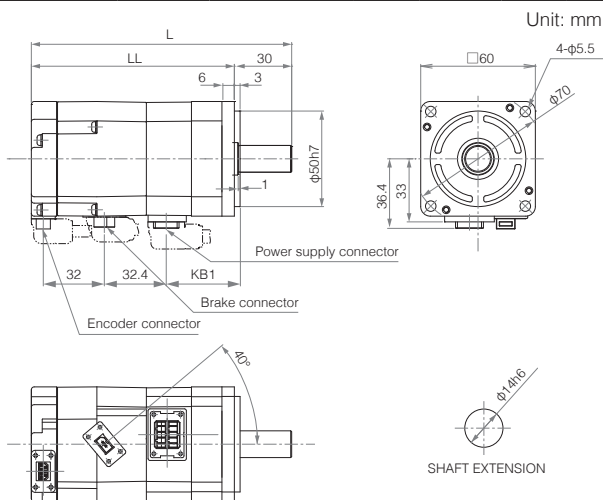

Unit: mm

Rated speed	Applicable motor rated output	Type	Overall length		Terminal portion	Mass (kg)
			L	LL		
3000 r/min	0.2 kW	GYB201D7-□B2-D	136.3	106.3	KB1	1.3
	0.4 kW	GYB401D7-□B2-D	154.1	124.1	KB1	1.8

GYB Motor (with brake)

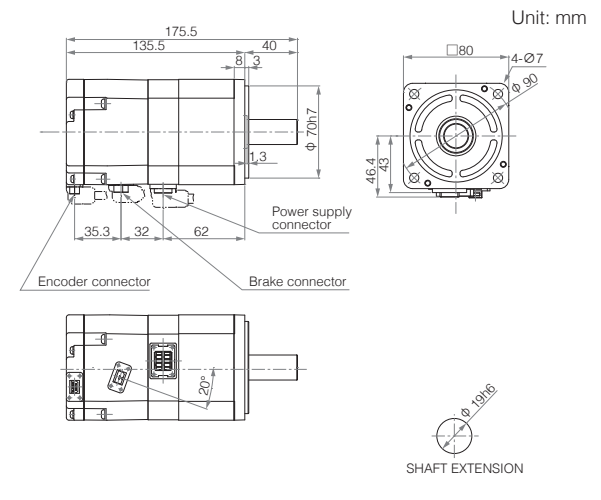

Unit: mm

Rated speed	Applicable motor rated output	Type	Mass (kg)
3000 r/min	0.75 kW	GYB751D7-□B2-D	3.2

\*See Page 33 for the shaft extension specifications of the motor with a key.

# External Dimensions: GYB Motor, lead wire type

GYB motor (without brake)

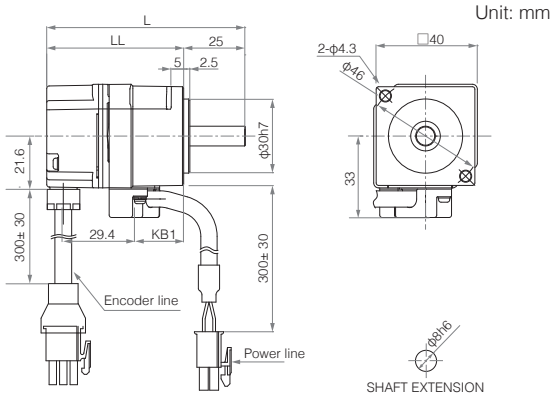

Rated speed	Applicable motor rated output	Type	Overall length		Mass (kg)
			L	LL	
3000 r/min	0.05 kW	GYB500D7-□B2	80.5	55.5	0.3
	0.1 kW	GYB101D7-□B2	92.5	67.5	0.4

GYB motor (without brake)

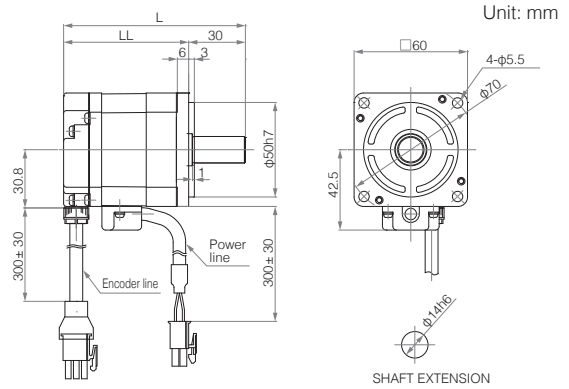

Rated speed	Applicable motor rated output	Type	Overall length		Mass (kg)
			L	LL	
3000 r/min	0.2 kW	GYB201D7-□B2	96.2	66.2	0.9
	0.4 kW	GYB401D7-□B2	114	84	1.2

GYB Motor (without brake)

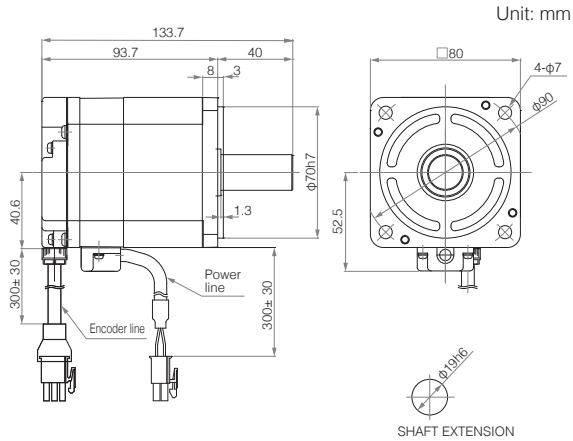

Rated speed	Applicable motor rated output	Type	Mass (kg)
3000 r/min	0.75 kW	GYB751D7-□B2	2.3

GYB motor (with brake)

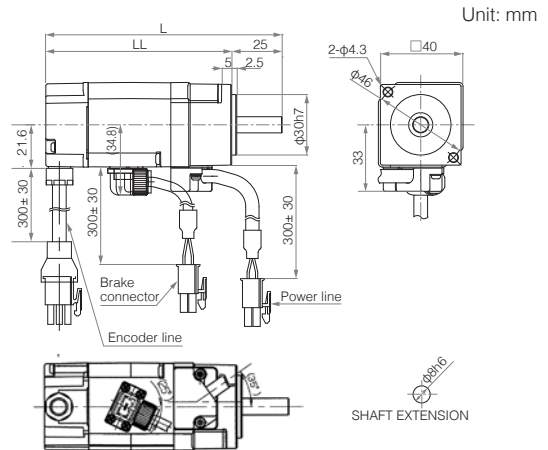

Rated speed	Applicable motor rated output	Type	Overall length		Mass (kg)
			L	LL	
3000 r/min	0.05 kW	GYB500D7-□B2-B	117.2	92.2	0.55
	0.1 kW	GYB101D7-□B2-B	129.2	104.2	0.65

GYB motor (with brake)

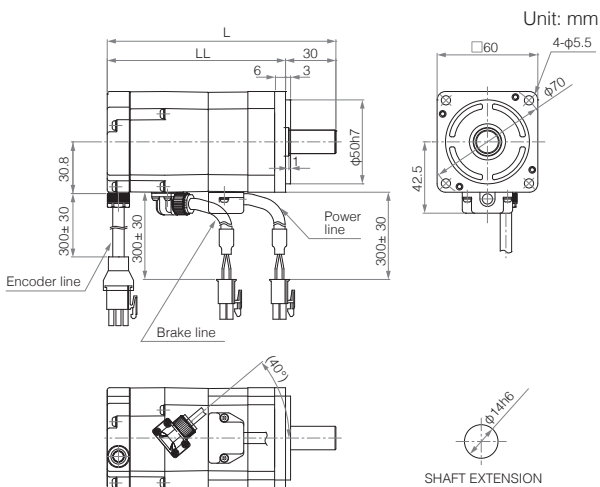

Rated speed	Applicable motor rated output	Type	Overall length		Mass (kg)
			L	LL	
3000 r/min	0.2 kW	GYB201D7-□B2-B	136.3	106.3	1.3
	0.4 kW	GYB401D7-□B2-B	154.1	124.1	1.8

GYB Motor (with brake)

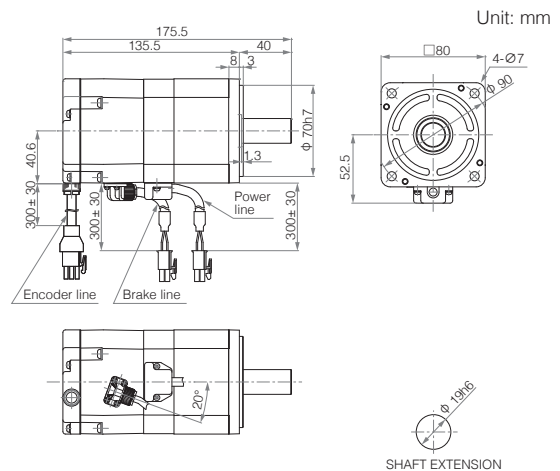

Rated speed	Applicable motor rated output	Type	Mass (kg)
3000 r/min	0.75 kW	GYB751D7-□B2-B	3.2

\*1 See Page 33 for the shaft extension specifications of the motor with a key.  
 \*2 Some dimensions may differ depending on the motor specifications.

# External Dimensions: GYE Motor

GYE motor (without brake)

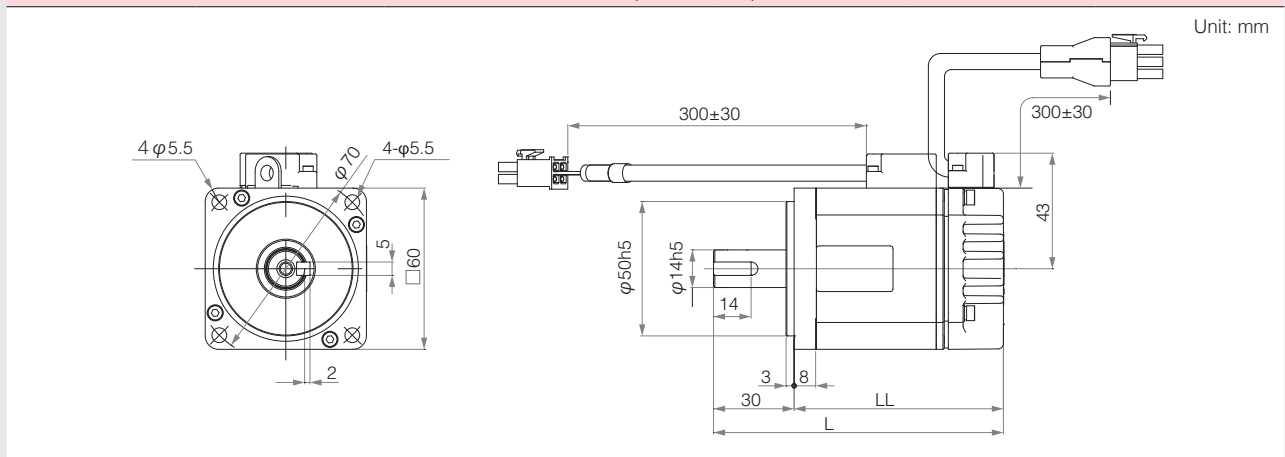

Rated speed	Applicable motor rated output	Type	Overall length	Dimension (flange)	Mass (kg)
			L	LL	
3000 r/min	0.2 kW	GYE201D6-GC2	107.9	77.9	0.9
	0.4 kW	GYE401D6-GC2	126.1	96.1	

GYE motor (without brake)

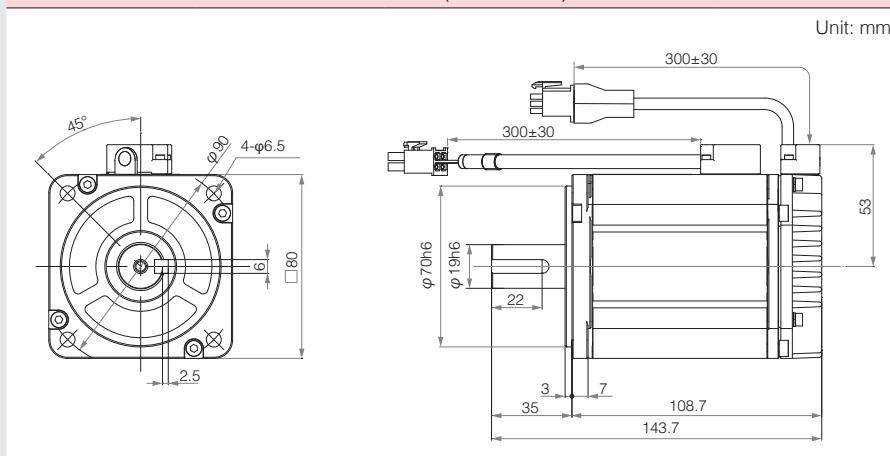

Rated speed	Applicable motor rated output	Type	Mass (kg)
3000 r/min	0.75 kW	GYE751D6-GC2	2.2

## Shaft Extension Specifications

Shaft extension specifications [with key, tapped]

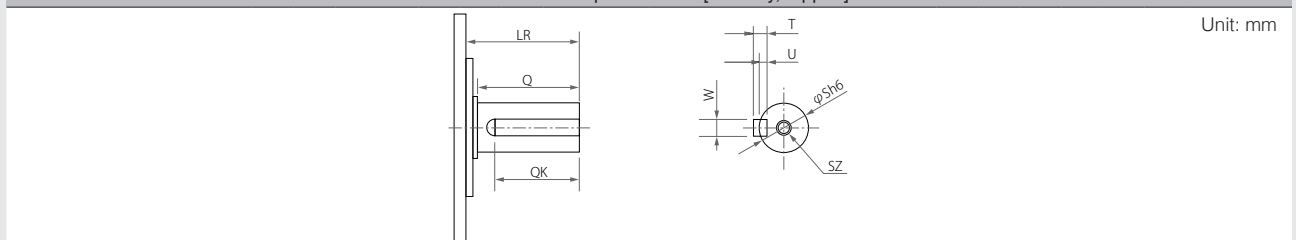

Motor type	LR	Q	QK	S	T	U	W	SZ	Motor type	LR	Q	QK	S	T	U	W	SZ
GYS motor 3000 r/min									GYB motor 3000 r/min								
GY500D7-□A2-□*	25	-	14	6	2	1.2	2	-	GYB500D7-□C2-□	25	-	14	8	3	2	3	M3 depth 6
GY510D7-□A2-□*	25	-	14	8	3	1.8	3	-	GYB101D7-□C2-□	25	-	14	8	3	2	3	M3 depth 8
GY5201D7-□C2-□	30	-	20	14	5	3	5	M5 depth 8	GYB201D7-□C2-□	30	-	14	14	5	3	5	M5 depth 8
GY5401D7-□C2-□	30	-	20	14	5	3	5	M5 depth 8	GYB401D7-□C2-□	30	-	14	14	5	3	5	M5 depth 8
GY5751D7-□C2-□	40	-	30	16	5	3	5	M5 depth 8	GYB751D7-□C2-□	40	-	22	19	6	3.5	6	M6 depth 10
GY5102D7-□C2-□	45	40	32	24	7	4	8	M8 depth 16									
GY5152D7-□C2-□	45	40	32	24	7	4	8	M8 depth 16									
GY5202D7-□C2-□	45	40	32	24	7	4	8	M8 depth 16									

\* The shaft extension of the GYS motors of 0.1 kW or less is not tapped.

# External Dimensions: GYL Motor

GYL motor (without brake)

Unit: mm

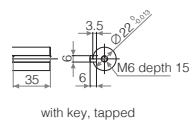

with key, tapped

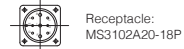
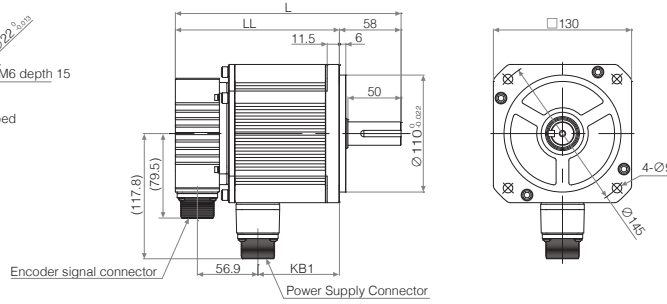

Encoder Signal Connector



Power Supply Connector

Rated speed	Applicable motor rated output	Type	Overall length		Dimension (flange)		Terminal portion	Mass (kg)
			L	LL	KB1			
1500 r/min	0.85 kW	GYL851B6-□G2	212.3	154.3	76.7		6.7	
	1.3 kW	GYL132B6-□G2	237.3	179.3	101.7		8.9	
	1.8 kW	GYL182B6-□G2	262.3	204.3	126.7		11.1	

GYL motor (without brake)

Unit: mm

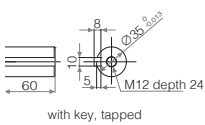

with key, tapped

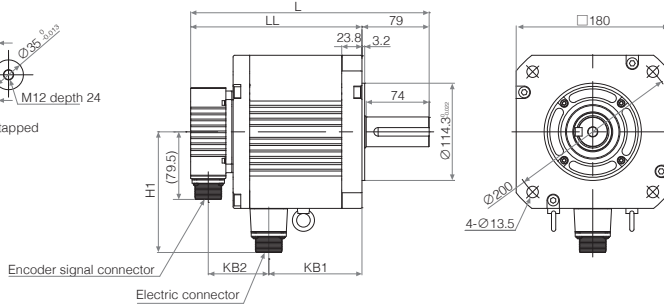

Encoder Signal Connector

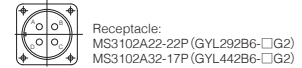

Power Supply Connector

Rated speed	Applicable motor rated output	Type	Overall length		Dimension (flange)			Terminal portion		Mass (kg)
			L	LL	KB1	KB2	H1			
1500 r/min	2.9 kW	GYL292B6-□G2	280.4	201.4	109.6	71.1	141.9	18		
	4.4 kW	GYL442B6-□G2	312.4	233.4	135.5	77.2	146.7	23.5		

GYL motor (with brake)

Unit: mm

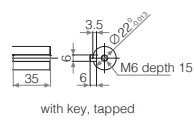

with key, tapped

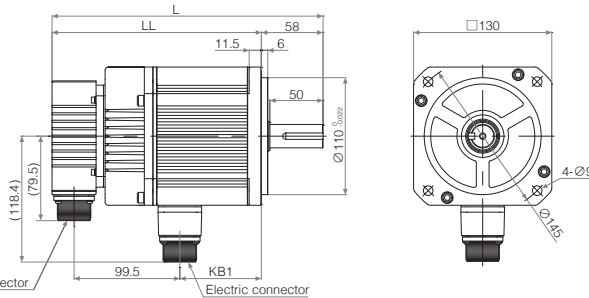

Encoder Signal Connector



Power Supply Connector

Rated speed	Applicable motor rated output	Type	Overall length		Dimension (flange)		Terminal portion	Mass (kg)
			L	LL	KB1			
1500 r/min	0.85 kW	GYL851B6-□G2-B	254.9	196.9	76.7		8.3	
	1.3 kW	GYL132B6-□G2-B	279.9	221.9	101.7		10.5	
	1.8 kW	GYL182B6-□G2-B	304.9	246.9	126.7		12.7	

GYL motor (without brake)

Unit: mm

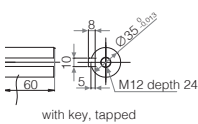

with key, tapped

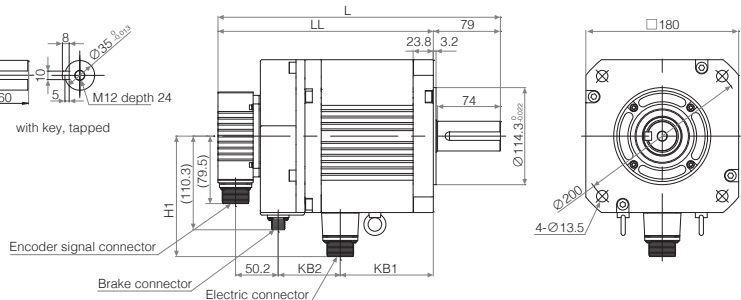

Encoder Signal Connector



Brake Connector

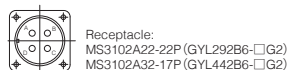

Power Supply Connector

Rated speed	Applicable motor rated output	Type	Overall length		Dimension (flange)			Terminal portion		Mass (kg)
			L	LL	KB1	KB2	H1			
1500 r/min	2.9 kW	GYL292B6-□G2-B	332.6	253.6	109.6	73.1	141.9	22.5		
	4.4 kW	GYL442B6-□G2-B	364.6	285.6	135.5	79.2	146.7	28		

# Options and Peripheral Equipment (ALPHA7S)

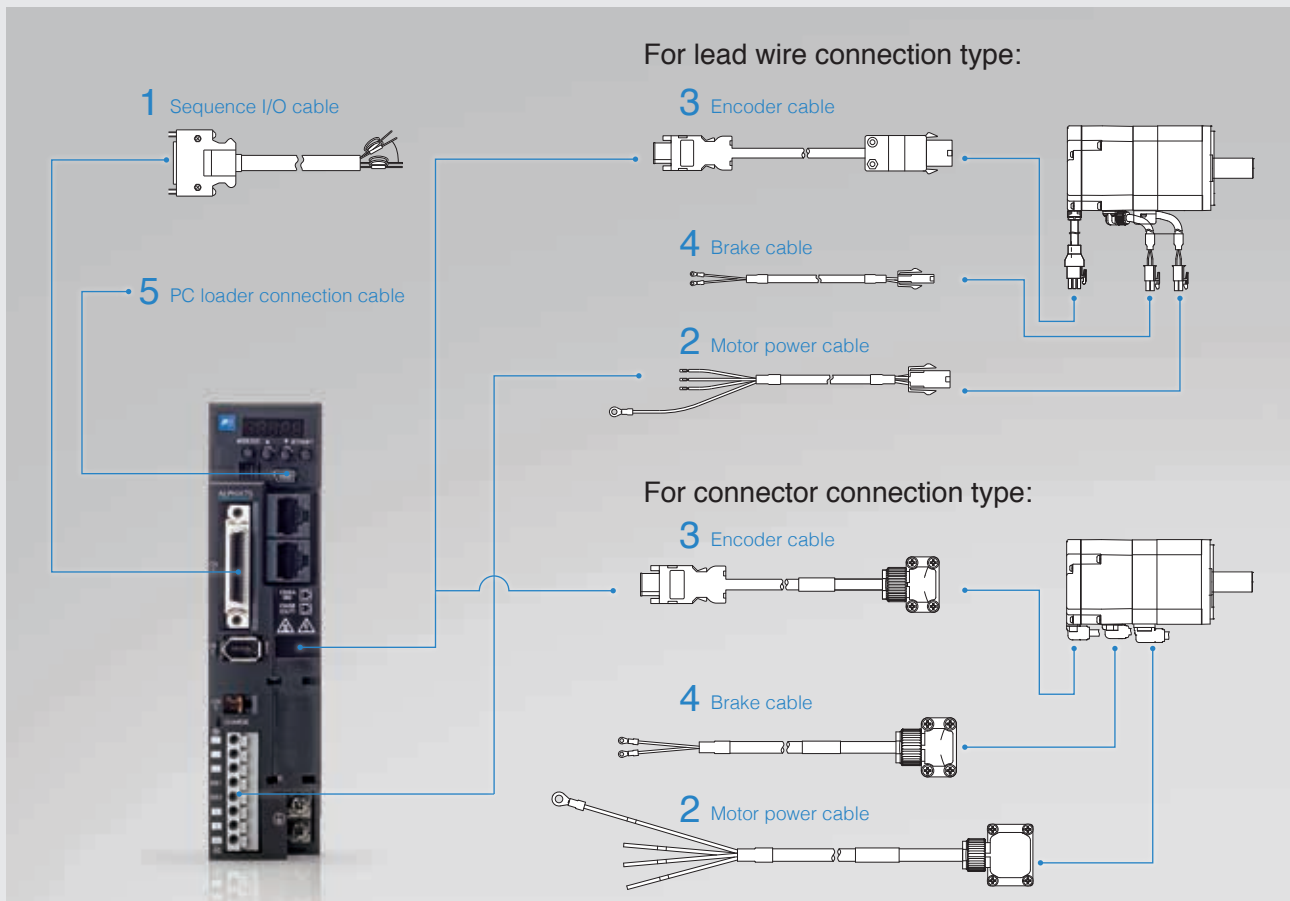

## Basic option

Motor series	Wire connection type	Brake	Rated output	1 Sequence I/O cable (between amplifier and motor)	2 Motor power cable (between amplifier and motor)	3 Encoder cable (between amplifier and motor)	4 Brake cable	5 PC loader cable		
GYS motor	Lead wire	No	0.05 kW to 0.75 kW	WSC-D36P03 (for VVS type)  WSC-D14P03 (for VCS type)  With connector, bare wires on one side, 3 m	WSC-M04P02-E WSC-M04P05-E WSC-M04P10-E WSC-M04P20-E	WSC-P06P02-E WSC-P06P05-E WSC-P06P10-E WSC-P06P20-E	-	USB Mini-B cable (commercially available one)		
		Yes					WSC-M02P02-E WSC-M02P05-E WSC-M02P10-E WSC-M02P20-E			
	Connector	No	WSC-M04P-CA is used to fabricate this (customer fabrication)				WSC-P06P05-C WSC-P06P10-C WSC-P06P20-C		-	
		Yes	WSC-M06P-CA is used to fabricate this (customer fabrication)				Wired to power supply connector			
GYB motor	Lead wire	No	0.05 kW to 0.75 kW	WSC-D36P03 (for VVS type)  WSC-D14P03 (for VCS type)  With connector, bare wires on one side, 3 m	WSC-M04P02-E WSC-M04P05-E WSC-M04P10-E WSC-M04P20-E	WSC-P06P02-E WSC-P06P05-E WSC-P06P10-E WSC-P06P20-E	-	USB Mini-B cable (commercially available one)		
		Yes					WSC-M02P02-E WSC-M02P05-E WSC-M02P10-E WSC-M02P20-E			
	Connector	No	0.05 kW to 0.75 kW				WSC-M04P02-K WSC-M04P05-K WSC-M04P10-K WSC-M04P20-K		WSC-P06P02-K WSC-P06P05-K WSC-P06P10-K WSC-P06P20-K	-
		Yes								WSC-M02P02-K WSC-M02P05-K WSC-M02P10-K WSC-M02P20-K
GYE motor	Lead wire	No	0.2 kW to 0.75 kW	WSC-M04P02-E WSC-M04P05-E WSC-M04P10-E WSC-M04P20-E	WSC-P06P02-E WSC-P06P05-E WSC-P06P10-E WSC-P06P20-E	-		USB Mini-B cable (commercially available one)		
GYL motor	Lead wire	No	0.85 kW to 4.4 kW			The connector shown on Page 36 is used to fabricate this (customer fabrication)				
		Yes								

# Options and Peripheral Equipment (ALPHA7S)

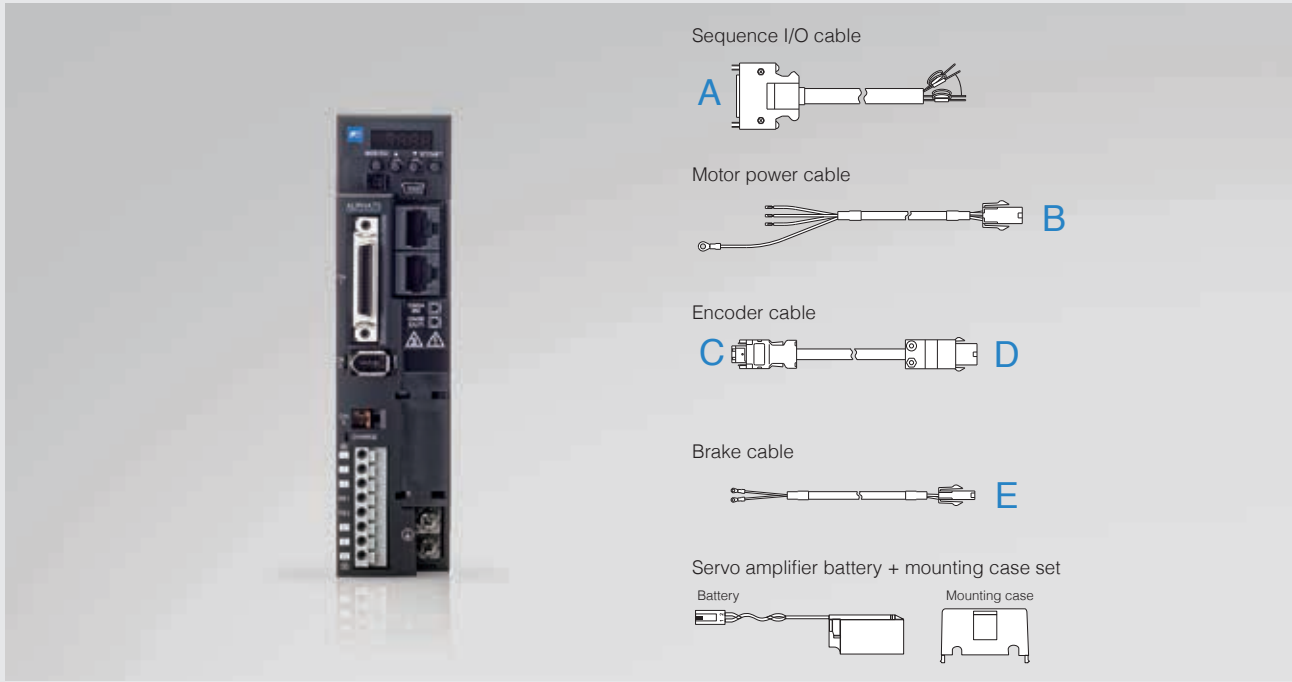

## Options (connector kits)

Motor series	Wire connection type	Brake	Rated output	A Sequence I/O connector	B Motor power connector (motor side)	C Encoder connector (amplifier side)	D Encoder connector (motor side)	E Brake connector
GYS motor	Lead wire	No	0.05 kW to 0.75 kW	WSK-D36P (for VVS type) WSK-D14P (for VCS type)	WSK-M04P-E	WSK-P06P-M	WSK-P09P-D	-
		Yes						WSK-M02P-E
Connector	No	1.0 kW to 2.0 kW	WSK-M04P-CA		WSK-P06P-C		-	
	Yes		WSK-M06P-CA				Wired to power supply connector	
GYB motor	Lead wire	No	0.05 kW to 0.75 kW		WSK-M04P-E		WSK-P09P-D	-
		Yes			WSK-M02P-E			
Connector	No	0.05 kW to 0.75 kW	-		-		-	
	Yes		-					
GYE motor	Lead wire	No	0.2 to 0.75 kW	WSK-M04P-E	WSK-P09P-D	-		
GYL motor	Connector	No	0.85 kW to 4.4 kW	The connector shown below is used to fabricate this (customer fabrication)	The connector shown below is used to fabricate this (customer fabrication)	-		
		Yes		The connector shown below is used to fabricate this (customer fabrication)				

## Recommended motor power connector

[Manufactured by DDK Ltd.]

Motor type	Motor mounted receptacle (For reference)	Products to be procured by customer		
		L-type plug	Straight plug	Cable clamp
GYL851B6-□□2(B)	MS3102A20-4P (MS3102A20-15P)	D/MS3108B20-4S (D/MS3108B20-15S)	D/MS3106B20-4S (D/MS3106B20-15S)	D/MS3057-12A
GYL132B6-□□2(B)				
GYL182B6-□□2(B)				
GYL292B6-□□2(B)	MS3102A22-22P	D/MS3108B22-22S	D/MS3106B22-22S	D/MS3057-12A
GYL442B6-□□2(B)	MS3102A32-17P	D/MS3108B32-17S	D/MS3106B32-17S	D/MS3057-20A

## Recommended brake power supply connector

[Manufactured by DDK Ltd.]

Motor type	Motor mounted receptacle (For reference)	Products to be procured by customer		
		L-type plug	Straight plug	Cable clamp
GYL292B6-□□2-B GYL442B6-□□2-B	MS3102A10SL-3P	D/MS3108B10SL-3S	D/MS3106B10SL-3S	D/MS3057-4A

## Wire size for wiring

Motor type	Motor power (U, V, W)	Brake
GYL851B6-□□2(B)	1.25	1.25
GYL132B6-□□2(B)	2	
GYL182B6-□□2(B)		
GYL292B6-□□2(B)	3.5	
GYL442B6-□□2(B)		

\*The above wire sizes are selected based on 75°C (HIV) wire. To use other wires, please refer to the user's manual.

## Peripherals

Input power	Servo amplifier type	Applicable motor rated output [kW]	Power filter	AC reactor	DC reactor	Molded case circuit breaker	Earth leakage circuit breaker	Magnetic contactor
Single-phase 200 V	RYT101S7-□□S2	0.1	RNFTD06-20	ACR2-0.4A	DCR2-0.4	BW32AAG-2P003	EW32AAG-2P003	SC-03
	RYT201S7-□□S2	0.2		ACR2-0.75A	DCR2-0.75	BW32AAG-2P005	EW32AAG-2P005	
	RYT401S7-□□S2	0.4	RNFTD10-20	ACR2-1.5A	DCR2-1.5	BW32AAG-2P010	EW32AAG-2P010	SC-0
	RYT751S7-□□S2	0.75	RNFTD20-20	ACR2-2.2A	DCR2-2.2	BW32AAG-2P015	EW32AAG-2P015	
3-phase 200 V	RYT101S7-□□S2	0.1	RNFTC06-20	ACR2-0.4A	DCR2-0.2	BW32AAG-3P003	EW32AAG-3P003	SC-03
	RYT201S7-□□S2	0.2			DCR2-0.4			
	RYT401S7-□□S2	0.4	RNFTC10-2	ACR2-0.75A	DCR2-0.75	BW32AAG-3P005	EW32AAG-3P005	
	RYT751S7-□□S2	0.75		ACR2-1.5A	DCR2-1.5	BW32AAG-3P010	EW32AAG-3P010	
	RYT851S7-□□S2	0.85	RNFTC20-20	ACR2-2.2A	DCR2-2.2	BW32AAG-3P015	EW32AAG-3P015	SC-4-1
	RYT132S7-□□S2	1.3				BW32AAG-3P020	EW32AAG-3P020	
	RYT182S7-□□S2	1.8	RNFTC30-20	ACR2-3.7A	DCR2-3.7	BW32AAG-3P030	EW32AAG-3P030	SC-N1
	RYT292S7-□□S2	2.9		ACR2-5.5A	DCR2-5.5	BW50AAG-3P040	EW50AAG-3P040	
RYT442S7-□□S2	4.4	RNFTC50-20	ACR2-11A	DCR2-11	BW50AAG-3P050	EW50AAG-3P050	SC-N2	

## External regenerative resistor option

The external regenerative resistor consumes regenerative power from the servomotor.  
Use an external regenerative resistor when the lifting load and operating frequency are high.

Servo amplifier type	Capacity [kW]	Built-in resistor*	External regenerative resistor	Applicable resistance [ $\Omega$ ]
RYT101S7-□□S2	0.1	-	WSR-401 (68 $\Omega$ , 17 W)	39 to 160
RYT201S7-□□S2	0.2	-		39 to 80
RYT401S7-□□S2	0.4	-		15 to 40
RYT751S7-□□S2	0.75	20 W/15 $\Omega$	WSR-152 (15 $\Omega$ , 50 W)	12 to 27
RYT851S7-□□S2	0.85			
RYT132S7-□□S2	1.3	30 W/12 $\Omega$	DB11-2 (10 $\Omega$ , 260 W)	7.5 to 20
RYT182S7-□□S2	1.8			7.5 to 13
RYT292S7-□□S2	2.9			
RYT442S7-□□S2	4.4	60 W/6 $\Omega$	DB22-2 (5.8 $\Omega$ , 300 W)	5.2 to 8

\*The maximum voltage of the built-in regenerative resistor varies depending on the ambient temperature.

# Model List: Servo Amplifiers (ALPHA7S)

Classification	Specification						Type
	Model	Control mode	Directive I/F	Input voltage	Frame	Capacity (kW)	
Amplifier	VVS type	Position, speed and torque control (Built-in positioning function)	General-purpose interface	Single-phase or 3-phase 200 to 240 V	Frame 1	0.1	RYT101S7-VVS2
						0.2	RYT201S7-VVS2
					0.4	RYT401S7-VVS2	
					Frame 2a	0.75	RYT751S7-VVS2
				3-phase 200 to 240 V	Frame 2b	0.85	RYT851S7-VVS2
						1.3	RYT132S7-VVS2
					Frame 3	1.8	RYT182S7-VVS2
	VCS type	Position, speed and torque control	EtherCAT	Single-phase or 3-phase 200 to 240 V	Frame 1	0.1	RYT101S7-VCS2
						0.2	RYT201S7-VCS2
					0.4	RYT401S7-VCS2	
					Frame 2a	0.75	RYT751S7-VCS2
				3-phase 200 to 240 V	Frame 2b	0.85	RYT851S7-VCS2
						1.3	RYT132S7-VCS2
					Frame 3	1.8	RYT182S7-VCS2
Frame 4	2.9	RYT292S7-VCS2					
Frame 4	4.4	RYT442S7-VCS2					

Features

Model Codes

Servo Amplifier Specifications

Connection Diagram for Reference

Servomotor Specifications

External Dimensions

Options and Peripheral Equipment

Model List

Product Warranty

# Model List: Servomotors

Classification	Specification								Type	
	Model	Voltage	Rated speed	Oil seal/Shaft	Encoder	Brake	Wire connection	Flange <input type="checkbox"/>		Applicable motor rated output (kW)
Motor	GYS motor (Ultra-low inertia)	200 V	3000 r/min	Without oil seal Straight shaft Without key *1	24-bit ABS	Without brake	Lead wire	<input type="checkbox"/> 40	0.05	GYS500D7-EB2
									0.1	GYS101D7-EB2
									0.2	GYS201D7-EB2
							Connector	<input type="checkbox"/> 60	0.4	GYS401D7-EB2
								<input type="checkbox"/> 80	0.75	GYS751D7-EB2
								<input type="checkbox"/> 100	1.0	GYS102D7-EB2
						With brake	Lead wire	<input type="checkbox"/> 40	1.5	GYS152D7-EB2
									2.0	GYS202D7-EB2
								<input type="checkbox"/> 60	0.05	GYS500D7-EB2-B
							Connector	<input type="checkbox"/> 60	0.1	GYS101D7-EB2-B
								<input type="checkbox"/> 80	0.2	GYS201D7-EB2-B
								<input type="checkbox"/> 100	0.4	GYS401D7-EB2-B
					24-bit INC	Without brake	Lead wire	<input type="checkbox"/> 40	0.75	GYS751D7-EB2-B
									1.0	GYS102D7-EB2-B
									1.5	GYS152D7-EB2-B
							Connector	<input type="checkbox"/> 40	2.0	GYS202D7-EB2-B
								<input type="checkbox"/> 60	0.05	GYS500D7-NB2
								<input type="checkbox"/> 80	0.1	GYS101D7-NB2
						With brake	Lead wire	<input type="checkbox"/> 60	0.2	GYS201D7-NB2
									0.4	GYS401D7-NB2
									0.75	GYS751D7-NB2
							Connector	<input type="checkbox"/> 60	1.0	GYS102D7-NB2
								<input type="checkbox"/> 80	1.5	GYS152D7-NB2
								<input type="checkbox"/> 100	2.0	GYS202D7-NB2

\*1 The table above shows representative models without an oil seal and without a key.

# Model List: Servomotors

Classification	Specification										Type	
	Model	Voltage	Rated speed	Oil seal/Shaft	Encoder	Brake	Wire connection	Flange <input type="checkbox"/>	Applicable motor rated output (kW)			
Motor	GYB motor (Medium inertia)	200 V	3000 r/min	Without oil seal Straight shaft Without key <sup>*1</sup>	24-bit ABS	Without brake	Connector	<input type="checkbox"/> 40	0.05	GYB500D7-EB2-C		
									0.1	GYB101D7-EB2-C		
									0.2	GYB201D7-EB2-C		
									0.4	GYB401D7-EB2-C		
									0.75	GYB751D7-EB2-C		
									0.05	GYB500D7-EB2-D		
						0.1		GYB101D7-EB2-D				
						0.2		GYB201D7-EB2-D				
						0.4		GYB401D7-EB2-D				
						0.75		GYB751D7-EB2-D				
						0.05		GYB500D7-NB2-C				
						0.1		GYB101D7-NB2-C				
					0.2	GYB201D7-NB2-C						
					0.4	GYB401D7-NB2-C						
					0.75	GYB751D7-NB2-C						
					0.05	GYB500D7-NB2-D						
					0.1	GYB101D7-NB2-D						
					0.2	GYB201D7-NB2-D						
					0.4	GYB401D7-NB2-D						
					0.75	GYB751D7-NB2-D						
					24-bit INC	Without brake	Lead wire	<input type="checkbox"/> 40	0.05	GYB500D7-EB2		
									0.1	GYB101D7-EB2		
									0.2	GYB201D7-EB2		
									0.4	GYB401D7-EB2		
	0.75	GYB751D7-EB2										
	0.05	GYB500D7-EB2-B										
	0.1	GYB101D7-EB2-B										
	0.2	GYB201D7-EB2-B										
	0.4	GYB401D7-EB2-B										
	0.75	GYB751D7-EB2-B										
	With brake	Lead wire	<input type="checkbox"/> 40	0.05		GYB500D7-NB2						
				0.1		GYB101D7-NB2						
				0.2	GYB201D7-NB2							
				0.4	GYB401D7-NB2							
				0.75	GYB751D7-NB2							
				0.05	GYB500D7-NB2-B							
0.1	GYB101D7-NB2-B											
0.2	GYB201D7-NB2-B											
0.4	GYB401D7-NB2-B											
0.75	GYB751D7-NB2-B											
24-bit ABS	Without brake		Lead wire	<input type="checkbox"/> 60	0.2	GYE201D6-GC2						
					0.4	GYE401D6-GC2						
		0.75			GYE751D6-GC2							
	With brake	<input type="checkbox"/> 60			0.85	GYL851B6-PG2						
					1.3	GYL132B6-PG2						
					1.8	GYL182B6-PG2						
17-bit ABS	Without brake			Connector	<input type="checkbox"/> 130	2.9	GYL292B6-PG2					
						4.4	GYL442B6-PG2					
						0.85	GYL851B6-PG2-B					
	1.3	GYL132B6-PG2-B										
	1.8	GYL182B6-PG2-B										
	2.9	GYL292B6-PG2-B										
4.4	GYL442B6-PG2-B											
17-bit INC	Without brake	Connector	<input type="checkbox"/> 180		0.85	GYL851B6-TG2						
					1.3	GYL132B6-TG2						
					1.8	GYL182B6-TG2						
	With brake				<input type="checkbox"/> 130	2.9	GYL292B6-TG2					
						4.4	GYL442B6-TG2					
				0.85		GYL851B6-TG2-B						
1.3	GYL132B6-TG2-B											
1.8	GYL182B6-TG2-B											
2.9	GYL292B6-TG2-B											
GYE	200 V		3000 r/min	Without oil seal Straight shaft With key, tapped	17-bit INC	Without brake	Lead wire	<input type="checkbox"/> 60	0.2	GYE201D6-GC2		
									0.4	GYE401D6-GC2		
									0.75	GYE751D6-GC2		
		17-bit ABS							Connector	<input type="checkbox"/> 130	0.85	GYL851B6-PG2
											1.3	GYL132B6-PG2
											1.8	GYL182B6-PG2
With brake	<input type="checkbox"/> 130	2.9	GYL292B6-PG2									
		4.4	GYL442B6-PG2									
		0.85	GYL851B6-PG2-B									
1.3		GYL132B6-PG2-B										
1.8		GYL182B6-PG2-B										
17-bit INC		Connector	<input type="checkbox"/> 180	0.85	GYL851B6-TG2							
	1.3			GYL132B6-TG2								
	1.8			GYL182B6-TG2								
	Without brake			<input type="checkbox"/> 180	2.9	GYL292B6-TG2						
					4.4	GYL442B6-TG2						
					0.85	GYL851B6-TG2-B						
1.3	GYL132B6-TG2-B											
1.8	GYL182B6-TG2-B											
2.9	GYL292B6-TG2-B											
GYL motor (Medium inertia)	200 V		1500 r/min	With oil seal Straight shaft With key, tapped	17-bit ABS	Without brake	Connector	<input type="checkbox"/> 130	0.85	GYL851B6-PG2		
									1.3	GYL132B6-PG2		
									1.8	GYL182B6-PG2		
		With brake							<input type="checkbox"/> 130	2.9	GYL292B6-PG2	
										4.4	GYL442B6-PG2	
										0.85	GYL851B6-PG2-B	
1.3	GYL132B6-PG2-B											
1.8	GYL182B6-PG2-B											
17-bit INC	Connector	<input type="checkbox"/> 180	0.85	GYL851B6-TG2								
			1.3	GYL132B6-TG2								
			1.8	GYL182B6-TG2								
			Without brake	<input type="checkbox"/> 180	2.9	GYL292B6-TG2						
					4.4	GYL442B6-TG2						
					0.85	GYL851B6-TG2-B						
1.3		GYL132B6-TG2-B										
1.8		GYL182B6-TG2-B										
2.9		GYL292B6-TG2-B										
17-bit INC		Connector	<input type="checkbox"/> 180	0.85	GYL851B6-TG2							
				1.3	GYL132B6-TG2							
				1.8	GYL182B6-TG2							
	Without brake			<input type="checkbox"/> 180	2.9	GYL292B6-TG2						
					4.4	GYL442B6-TG2						
					0.85	GYL851B6-TG2-B						
1.3	GYL132B6-TG2-B											
1.8	GYL182B6-TG2-B											
2.9	GYL292B6-TG2-B											

\*1 The table above shows representative models without an oil seal and without a key.

# Model List: Options

Classification	Name		Applicable	Specification	Type		
Options	Sequence I/O (between host and amplifier)	Sequence I/O cable		ALPHA7S VVS	3 m (bare wires on one side)	WSC-D36P03	
				ALPHA7S VCS		WSC-D14P03	
		Sequence I/O connector <sup>*1</sup>		ALPHA7S VVS	1 set	WSK-D36P	
				ALPHA7S VCS		WSK-D14P	
	For motor power	Motor power cable	For main power	GYS: 0.05 to 0.75 kW GYB: 0.05 to 0.75 kW GYE: 0.2 to 0.75 kW (Lead wire type)	2 m (bare wires on one side)	WSC-M04P02-E	
				5 m (bare wires on one side)	WSC-M04P05-E		
				10 m (bare wires on one side)	WSC-M04P10-E		
				20 m (bare wires on one side)	WSC-M04P20-E		
				2 m (bare wires on one side)	WSC-M04P02-K		
				5 m (bare wires on one side)	WSC-M04P05-K		
			10 m (bare wires on one side)	WSC-M04P10-K			
			20 m (bare wires on one side)	WSC-M04P20-K			
			For brake power	GYS: 0.05 to 0.75 kW GYB: 0.05 to 0.75 kW (Connector type)	2 m (bare wires on one side)	WSC-M02P02-E	
				5 m (bare wires on one side)	WSC-M02P05-E		
				10 m (bare wires on one side)	WSC-M02P10-E		
				20 m (bare wires on one side)	WSC-M02P20-E		
		2 m (bare wires on one side)		WSC-M02P02-K			
		5 m (bare wires on one side)		WSC-M02P05-K			
		10 m (bare wires on one side)	WSC-M02P10-K				
		20 m (bare wires on one side)	WSC-M02P20-K				
		For motor power <sup>*2</sup>	For main power	GYS/GYB: 0.05 to 0.75 kW <sup>2</sup> GYE: 0.2 to 0.75 kW	1 set	WSK-M04P-E	
				For brake power	GYS/GYB: 0.05 to 0.75 kW <sup>2</sup>	1 set	WSK-M02P-E
				For main power	GYS: 1.0 to 2.0 kW	1 set	WSK-M04P-CA
		For encoder (between amplifier and motor)	For main power + brake power	GYS: 1.0 to 2.0 kW	1 set	WSK-M06P-CA	
				Encoder cable	GYS/GYB: 0.05 to 0.75 kW GYE: 0.2 to 0.75 kW	10 m	WSC-P06P10-K
					20 m	WSC-P06P20-K	
			GYS: 1.0 to 2.0 kW		5 m	WSC-P06P05-C	
			Encoder connector <sup>*1</sup>	10 m	WSC-P06P10-C		
	20 m			WSC-P06P20-C			
	All capacities	1 set		WSK-P06P-M			
	Battery for ABS backup	Battery + mounting case set * With mounting case		1 set	WSB-SC		
		Battery * Replacement battery only		1 piece	WSB-S		
External regenerative resistor	ALPHA7S: 0.1 to 0.4 kW		1 piece	WSR-401			
	ALPHA7S: 0.75 to 1.3 kW		1 piece	WSR-152			
	ALPHA7S: 1.8 to 2.9 kW		1 piece	DB11-2			
	ALPHA7S: 4.4 kW		1 piece	DB22-2			

\*1 This connector is intended for use when the customer fabricates a cable of an arbitrary length. \*2 This is not necessary for GYB motors, connector type.

## Replacement of other models

We have prepared documents on how to replace other models with ALPHA7S.  
For details, please download the following documents from Download Documents for free.

Models applicable for replacement	Document No.	Document name
ALPHA5 Smart	Jde030-00801	ALPHA5 Smart Replacement Manual

## Gearhead Combination Table

Applicable motor	Capacity [kW]	Compatible servomotor type	Deceleration ratio 1/5		Deceleration ratio 1/9		Deceleration ratio 1/15		Deceleration ratio 1/25	
			Reduction gear type	Reduction gear part number code	Reduction gear type	Reduction gear part number code	Reduction gear type	Reduction gear part number code	Reduction gear type	Reduction gear part number code
GYS GYB	0.05	GYS500D7-○□2-△	GYN500SCG-G05XD	GYN300S	GYN500SCG-G09XD	GYN320S	GYN500SCG-G15XD	GYN360S	GYN500SCG-G25XD	GYN340S
		GYB500D7-○□2-△								
	0.1	GYS101D7-○□2-△	GYN101SCG-G05XD	GYN301S	GYN101SCG-G09XD	GYN321S	GYN101SCG-G15XD	GYN361S	GYN101SCG-G25XD	GYN341S
		GYB101D7-○□2-△								
	0.2	GYS201D7-○□2-△	GYN201SCG-G05XD	GYN302S	GYN201SCG-G09XD	GYN322S	GYN201SCG-G15XD	GYN362S	GYN201SCG-G25XD	GYN342S
		GYB201D7-○□2-△								
	0.4	GYS401D7-○□2-△	GYN401SCG-G05XD	GYN303S	GYN401SCG-G09XD	GYN323S	GYN401SCG-G15XD	GYN363S	GYN401SCG-G25XD	GYN343S
		GYB401D7-○□2-△								
	0.75	GYS751D7-○□2-△	GYN751SCG-G05XD	GYN304S	GYN751SCG-G09XD	GYN324S	GYN751SCG-G15XD	GYN364S	GYN751SCG-G25XD	GYN344S
		GYB751D7-○□2-△	GYN751BCG-G05XD <sup>*1</sup>	GYN301B	GYN751BCG-G09XD <sup>*1</sup>	GYN302B	GYN751BCG-G15XD <sup>*1</sup>	GYN304B	GYN751BCG-G25XD <sup>*1</sup>	GYN303B
	1	GYS102D7-○□2-△	-	-					-	-
	1.5	GYS152D7-○□2-△	-	-	GYN202SCG-G09XD	GYN325S	GYN202SCG-G15XD	GYN365S	-	-
	2	GYS202D7-○□2-△	-	-					-	-

\*1: The hole diameter of the motor insertion part is different.

- The symbols ○, □, △ in the nomenclature are explained below.

○	Encoder type	E	24-bit ABS
		N	24-bit INC
□	Shaft extension *Motors with E, F, or G oil seals cannot be used.	A	Without oil seal, straight shaft, with key
		B	Without oil seal, straight shaft, without key
		C	Without oil seal, straight shaft, with key, tapped
△	Connection/brake	Unmarked	Lead wire/without brake
		B	Lead wire/with brake
		C	Connector/without brake
		D	Connector/with brake

Note) By removing the key from the shaft, it can be assembled with a key-equipped motor.  
(The assembly work should be done by the customer.)

# Gearhead Dimensions: For GYS and GYB Motors

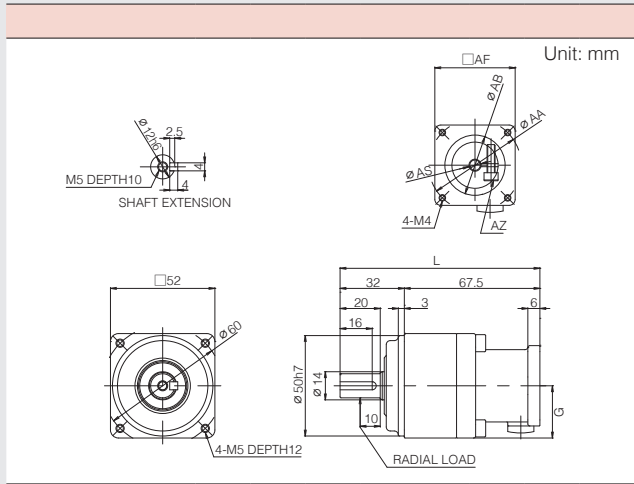

Type	Dimensions							Mass (kg)
	L	AF	AA	AZ	AB	AS	G	
GYN500SCG-G05XD	99.5					6	23.5	0.55
GYN500SCG-G09XD						6		
GYN500SCG-G15XD	110	40	46	M4	30	8	23.5	0.7
GYN500SCG-G25XD						8		
GYN101SCG-G05XD	99.5					6	23.5	0.55
GYN101SCG-G09XD						6		
GYN101SCG-G15XD	110	40	46	M4	30	8	23.5	0.7
GYN101SCG-G25XD						8		
GYN201SCG-G05XD	104.5	60	70	M5	50	14	33.5	0.72

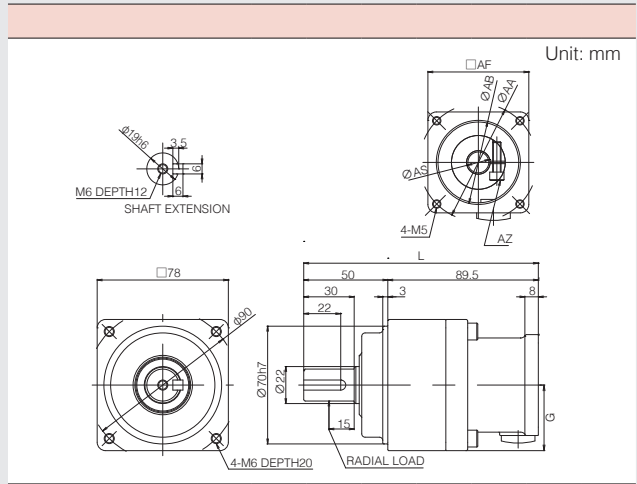

Type	Dimensions							Mass (kg)
	L	AF	AA	AZ	AB	AS	G	
GYN201SCG-G09XD	139.5							1.7
GYN201SCG-G15XD	150							2.1
GYN201SCG-G25XD	150							2.1
GYN401SCG-G05XD	139.5	90	70	M5	50	14	34.5	1.7
GYN401SCG-G09XD								
GYN401SCG-G15XD	150	90	70	M5	50	14	34.5	2.1
GYN401SCG-G25XD								
GYN751SCG-G05XD	143.5	80	90	M6	70	16	44.5	
GYN751BCG-G05XD						19		

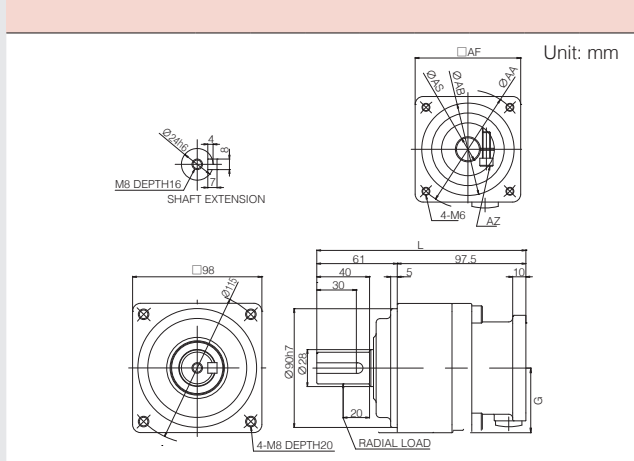

Type	Dimensions							Mass (kg)
	L	AF	AA	AZ	AB	AS	G	
GYN751SCG-G09XD	158.5					16	44.5	3.4
GYN751BCG-G09XD						19		
GYN751SCG-G15XD	171	80	90	M6	70	16	44.5	3.8
GYN751BCG-G15XD						19		
GYN751SCG-G25XD	171	80	90	M6	70	16	44.5	3.8
GYN751BCG-G25XD						19		

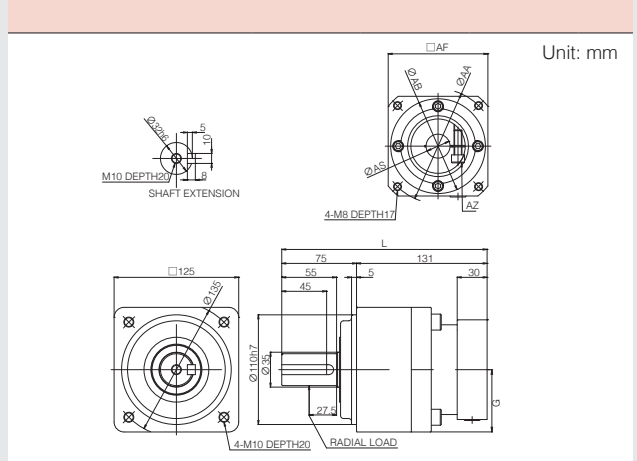

Type	Dimensions							Mass (kg)
	L	AF	AA	AZ	AB	AS	G	
GYN202SCG-G09XD	206	100	115	M8	95	24	51	7.1
GYN202SCG-G15XD	222	100	115	M8	95	24	51	8.4

# Specification List

## Common

Backlash	0.25° (15)
Degree of protection	IP40

## Deceleration ratio: 1/5

Reduction gear type (GYS and GYB)	GYN500SCG-G05XD	GYN101SCG-G05XD	GYN201SCG-G05XD	GYN401SCG-G05XD	GYN751SCG-G05XD
	GYN751BCG-G05XD				
Applicable motor capacity [kW]	0.05	0.1	0.2	0.4	0.75
Output shaft rated rotation speed [min <sup>-1</sup> ]	600				
Output shaft rated torque [N·m]	0.652	1.43	2.93	5.60	11.0
Output shaft instantaneous maximum torque [N·m]	1.96	4.29	8.78	16.8	32.9
Allowable radial load [N]	490				980
Allowable thrust load [N]	245				490
Motor shaft converted moment of inertia (GYS and GYB) [kg m <sup>2</sup> ]	0.0604×10 <sup>-4</sup>		0.147×10 <sup>-4</sup>	0.370×10 <sup>-4</sup>	0.817×10 <sup>-4</sup>

## Deceleration ratio: 1/9

Reduction gear type (GYS and GYB)	GYN500SCG-G09XD	GYN101SCG-G09XD	GYN201SCG-G09XD	GYN401SCG-G09XD	GYN751SCG-G09XD
	GYN751BCG-G09XD				
Applicable motor capacity [kW]	0.05	0.1	0.2	0.4	0.75
Output shaft rated rotation speed [min <sup>-1</sup> ]	333				
Output shaft rated torque [N·m]	1.17	2.58	4.75	10.1	19.5
Output shaft instantaneous maximum torque [N·m]	3.52	7.73	14.3	30.2	58.6
Allowable radial load [N]	588			1,180	1,470
Allowable thrust load [N]	294			588	735
Motor shaft converted moment of inertia (GYS and GYB) [kg m <sup>2</sup> ]	0.0497×10 <sup>-4</sup>		0.273×10 <sup>-4</sup>		0.755×10 <sup>-4</sup>

Reduction gear type (GYS and GYB)	GYN202SCG-G09XD		
Applicable motor capacity [kW]	1.0	1.5	2.0
Output shaft rated rotation speed [min <sup>-1</sup> ]	333		
Output shaft rated torque [N·m]	26.3	39.9	53.8
Output shaft instantaneous maximum torque [N·m]	79.0	120	162
Allowable radial load [N]	1,960		
Allowable thrust load [N]	980		
Motor shaft converted moment of inertia (GYS and GYB) [kg m <sup>2</sup> ]	2.75×10 <sup>-4</sup>		

## Deceleration ratio: 1/15

Reduction gear type (GYS and GYB)	GYN500SCG-G15XD	GYN101SCG-G15XD	GYN201SCG-G15XD	GYN401SCG-G15XD	GYN751SCG-G15XD
	GYN751BCG-G15XD				
Applicable motor capacity [kW]	0.05	0.1	0.2	0.4	0.75
Output shaft rated rotation speed [min <sup>-1</sup> ]	200				
Output shaft rated torque [N·m]	1.84	4.10	8.20	17.0	31.9
Output shaft instantaneous maximum torque [N·m]	5.51	12.3	24.6	51.0	95.6
Allowable radial load [N]	784			1,470	1,760
Allowable thrust load [N]	392			735	882
Motor shaft converted moment of inertia (GYS and GYB) [kg m <sup>2</sup> ]	0.0525×10 <sup>-4</sup>		0.302×10 <sup>-4</sup>		0.685×10 <sup>-4</sup>

Reduction gear type (GYS and GYB)	GYN202SCG-G15XD		
Applicable motor capacity [kW]	1.0	1.5	2.0
Output shaft rated rotation speed [min <sup>-1</sup> ]	200		
Output shaft rated torque [N·m]	42.0	63.7	84.9
Output shaft instantaneous maximum torque [N·m]	126	191	255
Allowable radial load [N]	2,350		
Allowable thrust load [N]	1,180		
Motor shaft converted moment of inertia (GYS and GYB) [kg m <sup>2</sup> ]	2.83×10 <sup>-4</sup>		

## Deceleration ratio: 1/25

Reduction gear type (GYS and GYB)	GYN500SCG-G25XD	GYN101SCG-G25XD	GYN201SCG-G25XD	GYN401SCG-G25XD	GYN751SCG-G25XD
	GYN751BCG-G25XD				
Applicable motor capacity [kW]	0.05	0.1	0.2	0.4	0.75
Output shaft rated rotation speed [min <sup>-1</sup> ]	120				
Output shaft rated torque [N·m]	3.06	6.84	13.7	28.3	53.1
Output shaft instantaneous maximum torque [N·m]	9.18	20.5	41.0	85.0	159
Allowable radial load [N]	882			1,670	2,060
Allowable thrust load [N]	441			833	1,030
Motor shaft converted moment of inertia (GYS and GYB) [kg m <sup>2</sup> ]	0.0514×10 <sup>-4</sup>		0.293×10 <sup>-4</sup>		0.658×10 <sup>-4</sup>

## Product Warranty

### ❖ Please take the following items into consideration when placing your order.

When requesting an estimate and placing your orders for the products included in these materials, please be aware that any items such as specifications which are not specifically mentioned in the contract, catalog, specifications or other materials will be as mentioned below. In addition, the products included in these materials are limited in the use they are put to and the place where they can be used, etc., and may require periodic inspection. Please confirm these points with your sales representative or directly with this company. Furthermore, regarding purchased products and delivered products, we request that you take adequate consideration of the necessity of rapid receiving inspections and of product management and maintenance even before receiving your products.

## 1. Free of Charge Warranty Period and Warranty Range

### 1-1 Free of charge warranty period

- (1) The product warranty period is "1 year from the date of purchase" or 24 months from the manufacturing date imprinted on the name plate, whichever date is earlier.
- (2) However, in cases where the use environment, conditions of use, use frequency and times used, etc., have an effect on product life, this warranty period may not apply.
- (3) Furthermore, the warranty period for parts restored by Fuji Electric's Service Department is "6 months from the date that repairs are completed."

### 1-2 Warranty range

- (1) In the event that breakdown occurs during the product's warranty period which is the responsibility of Fuji Electric, Fuji Electric will replace or repair the part of the product that has broken down free of charge at the place where the product was purchased or where it was delivered. However, if the following cases are applicable, the terms of this warranty may not apply.
  - 1) The breakdown was caused by inappropriate conditions, environment, handling or use methods, etc. which are not specified in the catalog, operation manual, specifications or other relevant documents.
  - 2) The breakdown was caused by the product other than the purchased or delivered Fuji's product.
  - 3) The breakdown was caused by the product other than Fuji's product, such as the customer's equipment or software design, etc.
  - 4) Concerning the Fuji's programmable products, the breakdown was caused by a program other than a program supplied by this company, or the results from using such a program.
  - 5) The breakdown was caused by modifications or repairs affected by a party other than Fuji Electric.
  - 6) The breakdown was caused by improper maintenance or replacement using consumables, etc. specified in the operation manual or catalog, etc.
  - 7) The breakdown was caused by a chemical or technical problem that was not foreseen when making practical application of the product at the time it was purchased or delivered.
  - 8) The product was not used in the manner the product was originally intended to be used.
  - 9) The breakdown was caused by a reason which is not this company's responsibility, such as lightning or other disaster.
- (2) Furthermore, the warranty specified herein shall be limited to the purchased or delivered product alone.
- (3) The upper limit for the warranty range shall be as specified in item (1) above and any damages (damage to or loss of machinery or equipment, or lost profits from the same, etc.) consequent to or resulting from breakdown of the purchased or delivered product shall be excluded from coverage by this warranty.

### 1-3 Trouble diagnosis

As a rule, the customer is requested to carry out a preliminary trouble diagnosis. However, at the customer's request, this company or its service network can perform the trouble diagnosis on a chargeable basis. In this case, the customer is asked to assume the burden for charges levied in accordance with this company's fee schedule.

## 2. Exclusion of Liability for Loss of Opportunity, etc.

Regardless of whether a breakdown occurs during or after the free of charge warranty period, this company shall not be liable for any loss of opportunity, loss of profits, or damages arising from special circumstances, secondary damages, accident compensation to another company, or damages to products other than this company's products, whether foreseen or not by this company, which this company is not be responsible for causing.

## 3. Repair Period after Production Stop, Spare Parts Supply Period (Holding Period)

Concerning models (products) which have gone out of production, this company will perform repairs for a period of 7 years after production stop, counting from the month and year when the production stop occurs. In addition, we will continue to supply the spare parts required for repairs for a period of 7 years, counting from the month and year when the production stop occurs. However, if it is estimated that the life cycle of certain electronic and other parts is short and it will be difficult to procure or produce those parts, there may be cases where it is difficult to provide repairs or supply spare parts even within this 7-year period. For details, please confirm at our company's business office or our service office.

## 4. Transfer Rights

In the case of standard products which do not include settings or adjustments in an application program, the products shall be transported to and transferred to the customer and this company shall not be responsible for local adjustments or trial operation.

## 5. Service Contents

The cost of purchased and delivered products does not include the cost of dispatching engineers or service costs. Depending on the request, these can be discussed separately.

## 6. Applicable Scope of Service

Please inquiry the supplier or Fuji Electric China for details of above.

# MEMO



---

** Fuji Electric Co., Ltd.**

Gate City Ohsaki, East Tower, 11-2, Osaki 1-chome, Shinagawa-ku, Tokyo 141-0032, Japan  
Phone : (03)5435-7111

---

Internet address : <http://www.fujielectric.co.jp>

Information in this catalog is subject to change without notice.

2023-12(L2023/L2023)00FOLS Printed in Japan